



Ditec DAB205

Motorised swing

(translation of the original instructions)

IP2178EN
Technical Manual

Contents

	Subject	Page
1.	General safety precautions	3
2.	General safety precautions for the user	4
	Declaration of incorporation of partly completed machinery	5
	Revisions	6
3.	Technical specifications	7
4.	Standard installation	8
5.	Dimensions	9
6.	Main components	10
7.	Installation	11
7.1	Preliminary checks	11
7.2	General information	11
7.3	Examples of installation	12
7.4	Removing the cover	12
8.	DAB805PSA2 automation with articulated arm	13
8.1	Automation preparation and fastening	14
8.2	Fixing the arm	16
9.	Automation with sliding arm DAB805PLA2	17
9.1	Automation preparation and fastening	18
9.2	Fixing the arm	20
10.	Connecting to the electricity supply	21
11.	Starting up the door	22
12.	Electrical connections	23
12.1	Commands	23
12.2	Outputs and accessories	24
12.3	Adjustments	25
12.4	Alarms	27
13.	Pre-configured parameters	27
14.	Door requisites for Low Energy use	29
15.	Door requisites for transit of disabled people	29
16.	Example of an application with a standard automation	30
17.	Extension unit DAB905ESE (optional)	31
17.1	Commands	31
17.2	Outputs and accessories	33
17.3	Adjustments	34
17.4	Advanced settings available on the control panel version indicated, or subsequent versions	35
18.	Extension unit DAB905ESA (optional)	36
18.1	Commands	36
18.2	Outputs and accessories	37
18.3	Adjustments	38
19.	Example of an application with optional extension units	39
20.	Example of an application DAB905RSD	40
21.	Parallel (DAB905SYN) and interlocked automations	41
22.	Electrical start-up	44
23.	Routine maintenance plan	44
24.	Troubleshooting	45
25.	Signs	46

Key



This symbol indicates instructions or notes regarding safety, to which special attention must be paid.



This symbol indicates useful information for the correct functioning of the product.



This symbol advises you to contact the Technical Service.

1. General safety precautions



This installation manual is intended for qualified personnel only.

Installation, electrical connections and adjustments must be performed in accordance with Good Working Methods and in compliance with the present standards. Read the instructions carefully before installing the product.

Incorrect installation could be dangerous.



The packaging materials (plastic, polystyrene, etc.) should not be discarded in the environment or left within reach of children, as they are a potential source of danger. Before installing the product, make sure it is in perfect condition.

Do not install the product in explosive areas and atmospheres: the presence of inflammable gas or fumes represents a serious safety hazard.

Before installing the motorisation device, make all the necessary structural modifications to create safety clearance and to guard or isolate all the crushing, shearing, trapping and general hazardous areas.

Make sure the existing structure is up to standard in terms of strength and stability. The motorisation device manufacturer is not responsible for failure to observe Good Working Methods when building the frames to be motorised, or for any deformations during use.

The safety devices (photocells, safety edges, emergency stops, etc.) must be installed taking into account the applicable laws and directives, Good Working Methods, installation premises, system operating logic and the forces developed by the motorised door.



The safety devices must protect the crushing, shearing, trapping and general hazardous areas of the motorised door. Display the signs required by law to identify hazardous areas.

Each installation must bear a visible indication of the data identifying the motorised door.

When requested, connect the motorised door to an effective earthing system that complies with current safety standards. During installation, maintenance and repair operations, cut off the power supply before opening the cover to access the electrical parts.

The automation protection casing must be removed by qualified personnel only.



The electronic parts must be handled using earthed antistatic conductive arms. The manufacturer of the motorisation declines all responsibility if component parts not compatible with safe and correct operation are fitted.

Only use original spare parts when repairing or replacing products.

The installer must supply all information on the automatic, manual and emergency operation of the motorised door, and must provide the user with the operating instructions.

2. General safety precautions for the user



These precautions are an integral and essential part of the product and must be supplied to the user.

Read them carefully since they contain important information on safe installation, use and maintenance.

These instructions must be kept and forwarded to all possible future users of the system.

This product must only be used for the specific purpose for which it was designed.

Any other use is to be considered improper and therefore dangerous. The manufacturer cannot be held responsible for any damage caused by improper, incorrect or unreasonable use.

Avoid operating in the proximity of the hinges or moving mechanical parts. Do not enter within the operating range of the motorised door or gate while it is moving.

Do not obstruct the motion of the motorised door or gate, as this may cause a dangerous situation.

The motorised door or gate may be used by children over the age of 8 and by people with reduced physical, sensorial or mental abilities, or lack of experience or knowledge, as long as they are properly supervised or have been instructed in the safe use of the device and the relative hazards. Children must be supervised to make sure they do not play with the device, nor play/remain in the sphere of action of the motorised door or gate.

Keep remote controls and/or any other command devices out of the reach of children, to avoid any accidental activation of the motorised door or gate.

In the event of a product fault or malfunction, turn off the power supply switch. Do not attempt to repair or intervene directly, and contact only qualified personnel.

Failure to comply with the above may cause a dangerous situation.

Any repairs or technical interventions must be carried out by qualified personnel.

Cleaning and maintenance work must not be carried out by children unless they are supervised.

To ensure that the system works efficiently and correctly, the manufacturer's indications must be complied with and only qualified personnel must perform routine maintenance on the motorised door or gate. In particular, regular checks are recommended in order to verify that the safety devices are operating correctly.

All installation, maintenance and repair work must be documented and made available to the user.

Only lock and release the door wings when the motor is switched off. Do not enter within the operating range of the wing.



To dispose of electrical and electronic equipment correctly, users must take the product to special "recycling centres" provided by the municipal authorities.

Declaration of incorporation of partly completed machinery

We:
Entrematic Group AB
Lodjursgatan 10
SE-261 44 Landskrona
Sweden

declare under our responsibility that the following equipment:

Ditec DAB205

complies with the following directives:

2014/30/EU Electromagnetic Compatibility Directive (EMC)
2006/42/EC Machinery Directive (MD) for the following essential health and safety requirements: 1.1.2, 1.1.3, 1.2.1, 1.2.3, 1.2.4, 1.2.6, 1.3.2, 1.3.4, 1.5.1, 1.5.2, 1.5.3, 1.5.8, 1.5.9, 1.5.10, 1.5.11, 1.6.3, 1.7.3, 1.7.4.

Technical documentation for safe integration supplied.

Harmonised European standards which have been applied:

EN 60335 -1:2012 EN 61000 -6-2:2005 EN 61000 -6-3:2007+A1:2011 EN ISO 13849 -1:2008
EN 16005:2012 EN 60335-2-103:2003+A11:2009

Other standards or technical specifications, which have been applied:

BBR BVL IEC 60335-1: 2010 ed.5 IEC60335-2-103:2002 ed.1+2011 ed.2.1 EN1634-1:2008

CE type examination or certificate issued by a notified or competent body (for the full address, contact Entrematic Group AB) for the equipment:

SC0135-14

The production process aims to guarantee that the equipment complies with the technical documentation. The production process is regularly assessed by an independent body.

The equipment must not be put into service until the final door system installed has been declared compliant with the Machinery Directive 2006/42/EC by the installer.

Person in charge of technical data sheet:

Matteo Fino E-mail: matteo.fino@entrematic.com

Entrematic Group AB
Lodjursgatan 10
SE-261 44 Landskrona
Sweden

Place
Landskrona

Date
2017-05-02

Signature
Matteo Fino

Position
President Entrance Automation

Revisions

The following pages have been revised:

Page	Revision 2016-04-06 → 2017-06-14
12	Automation image
13	Dimensions changed for arm extension Y distance and arm fastening to gate wing
14	Arm fastening quota changed (288)
16-20	Instruction to always install stop ring added
23	GND-OPD description
25	Trimmer SPTE, CLTQ and POAS description
26	DIP1 description
27	Description of alarm 1 and 2
32	Description of GND-KILL contact
33	Description of the battery functions
35	Paragraph for advanced settings (increased thrust force on closure)
38	Trimmer description
40	Position of DAB905RSD fastening hole

3. Technical specifications

DAB205																																		
Power	100-240V~ +10/-15% 50/60 Hz																																	
Line fuse	max. 10A																																	
Consumption	max. 300W																																	
Power supply for accessories	24V = 700 mA max.																																	
F1 fuse	T6.3A / 250 V																																	
F2 fuse	T6.3A / 250 V																																	
Door wing width	700-1600mm																																	
Maximum wing weight	400 kg (see inertia graph)																																	
Inertia J = kgm² Inertia J = $\frac{\text{door weight} \times [\text{door width}]^2}{3}$ DAB805PSA2: 160kg m ² DAB805PLA2: 80kg m ²	<table border="1"> <caption>Approximate data from Inertia Graph</caption> <thead> <tr> <th>Door Width [m]</th> <th>DAB805PSA2 Door Weight [kg]</th> <th>DAB805PLA2 Door Weight [kg]</th> </tr> </thead> <tbody> <tr><td>0.7</td><td>400</td><td>300</td></tr> <tr><td>0.8</td><td>400</td><td>300</td></tr> <tr><td>0.9</td><td>400</td><td>300</td></tr> <tr><td>1.0</td><td>380</td><td>250</td></tr> <tr><td>1.1</td><td>350</td><td>200</td></tr> <tr><td>1.2</td><td>300</td><td>160</td></tr> <tr><td>1.3</td><td>260</td><td>130</td></tr> <tr><td>1.4</td><td>220</td><td>110</td></tr> <tr><td>1.5</td><td>190</td><td>100</td></tr> <tr><td>1.6</td><td>180</td><td>90</td></tr> </tbody> </table>	Door Width [m]	DAB805PSA2 Door Weight [kg]	DAB805PLA2 Door Weight [kg]	0.7	400	300	0.8	400	300	0.9	400	300	1.0	380	250	1.1	350	200	1.2	300	160	1.3	260	130	1.4	220	110	1.5	190	100	1.6	180	90
Door Width [m]	DAB805PSA2 Door Weight [kg]	DAB805PLA2 Door Weight [kg]																																
0.7	400	300																																
0.8	400	300																																
0.9	400	300																																
1.0	380	250																																
1.1	350	200																																
1.2	300	160																																
1.3	260	130																																
1.4	220	110																																
1.5	190	100																																
1.6	180	90																																
Door wing weight/width (kg/mm)	DAB805PSA2: max. 160/1600, EN 4-7 DAB805PLA2: max. 100/1250, EN 4-5																																	
Opening time	min. 2.5s / 0°-80° max. 12s / 0°-80° Variable from classification setting (see chapter 14)																																	
Closing time	min. 4s / 90°-10° max. 12s / 90°-10°																																	
Door wing opening angle	DAB805PSA2 articulated arm: 80°-110° DAB805PLA2 sliding arm: 80°-110°																																	
Type of operation	Motor opening Spring-plus-motor closure																																	
Fire barriers	Applicable using both movement arms																																	
Minimum number of manoeuvres in AVERAGE conditions of use	1,000,000 cycles																																	
Temperature	min. -20°C max. +45°C																																	
Relative humidity	max. 95%																																	
Degree of protection	IP20 (FOR INTERNAL USE ONLY)																																	

4. Standard installation

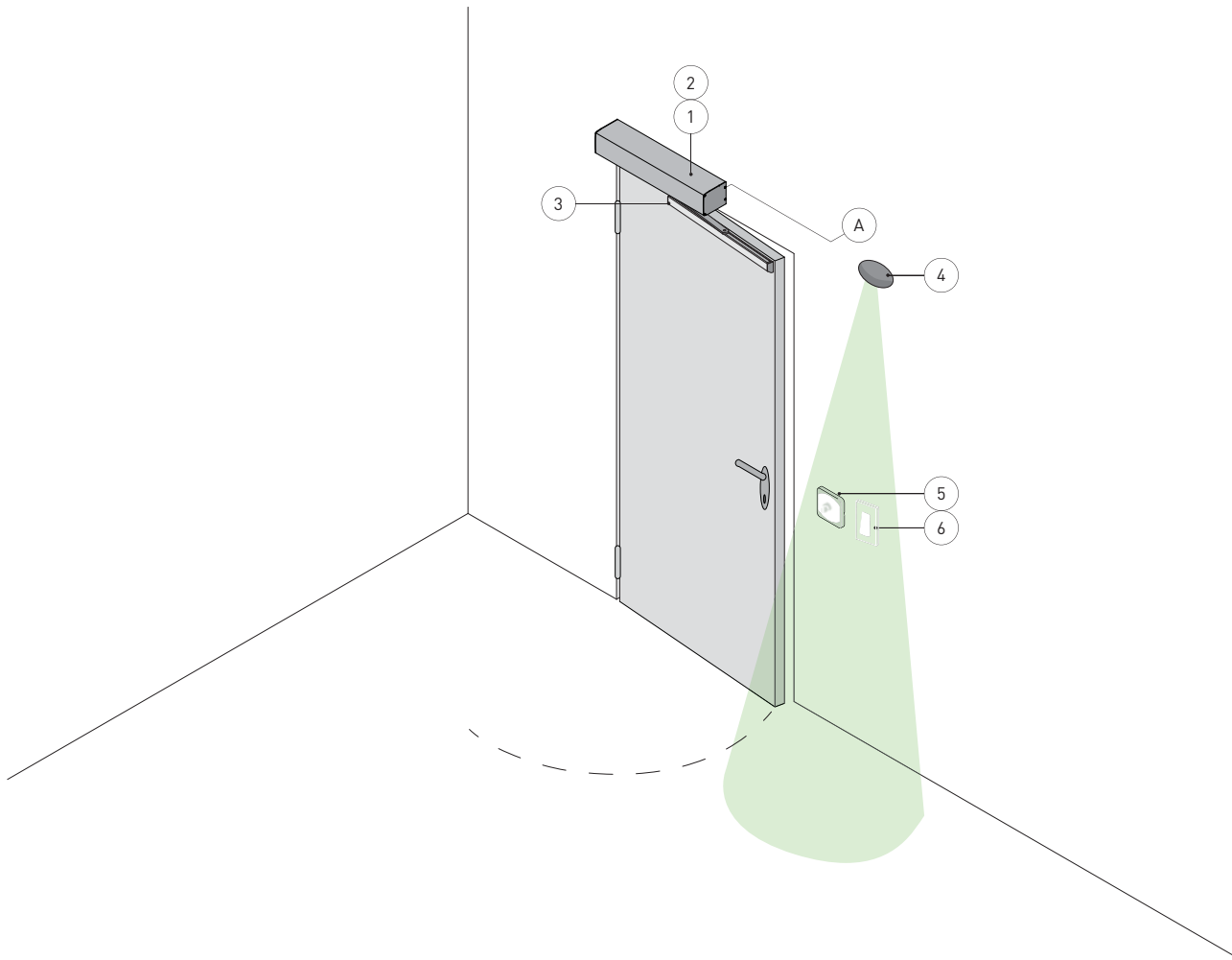

Ref.	Code	Description
1	DAB205	Electro-mechanical actuator
2		Control panel
3	DAB805PSA2 DAB805PLA2	Articulated movement arm (including for applications on fire barriers) Sliding movement arm (including for applications on fire barriers)
4		Opening sensor
5	COM400MHB COM400MKB	Function selector switch
6		Command button
A		Connect the power supply to a type-approved omnipolar switch, with a contact opening distance of at least 3mm (not supplied). Connection to the mains must be via an independent channel, separate from the connections to the control and safety devices.

5. Dimensions and references

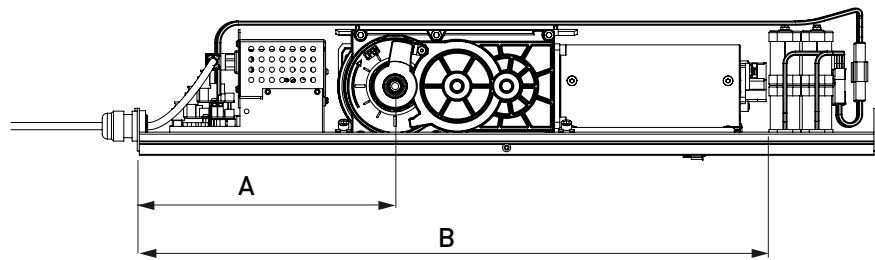
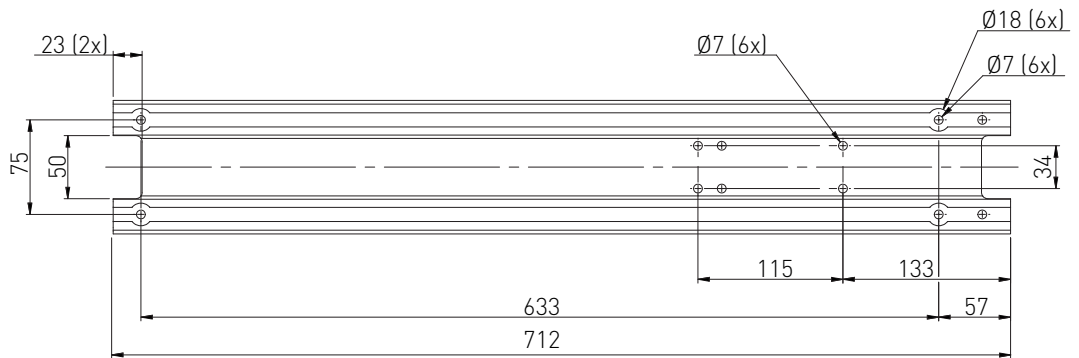
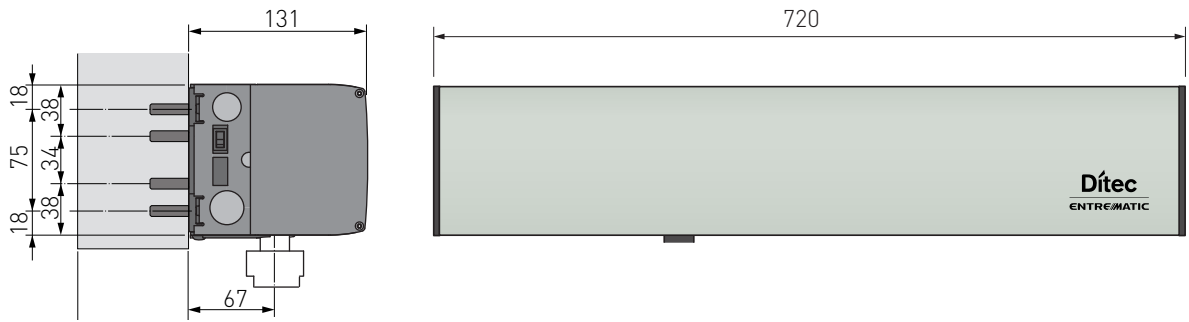

A	250mm
B	613mm
C	32mm

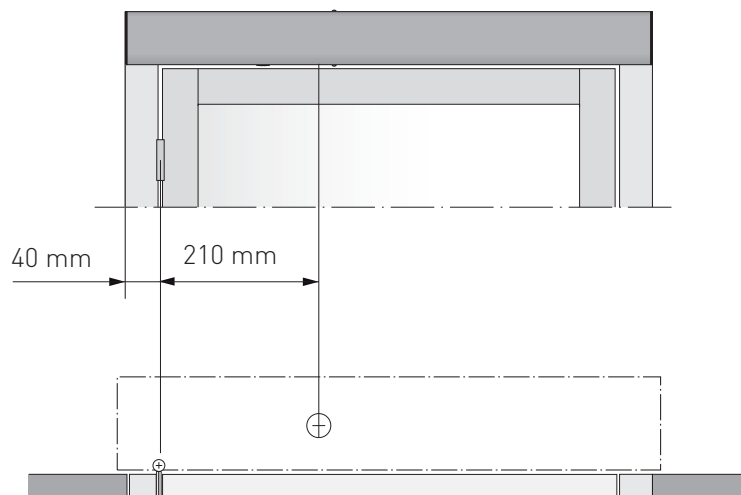
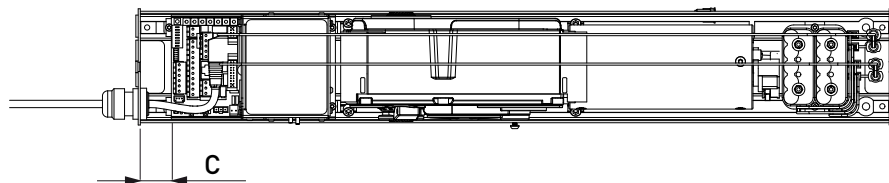

6. Main components

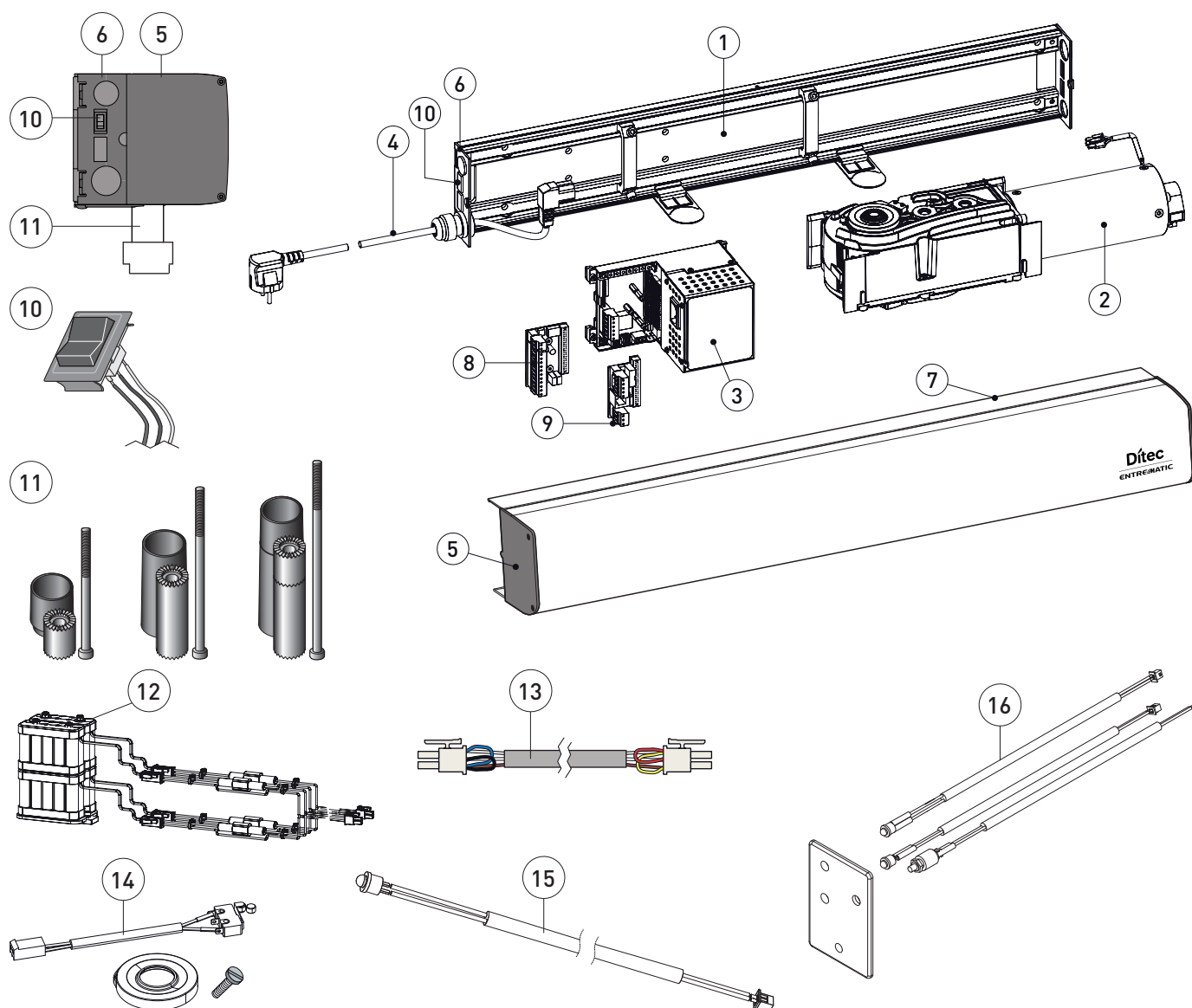

Ref.	Code	Description
1		Base plate
2		Gearmotor
3	DAB205CU	Control panel
4		Power
5		Upper head
6		Lower head
7		Casing
8	DAB905ESE	Safety and pulse extension card (optional)
9	DAB905ESA	Extension card for safety functions (optional)
10		ON/OFF/HOLD OPEN switch
11	DAB805SE22	Shaft extension - 20mm
	DAB805SE52	Shaft extension - 50mm
	DAB805SE72	Shaft extension - 70mm
12	DAB905BAT2	Battery kit
13	DAB905SYN	Synchronisation cable for parallel doors (L = 3000mm)
14	DAB905MSW	Kit with microswitch for electric lock / electric strike coupling
15	DAB905LED	Kit with alarm indication LED
16	DAB905RSD	Kit for RESET and fire alarm indication

7. Installation

The given operating and performance features can only be guaranteed with the use of DITEC Entrematic accessories and safety devices. Unless otherwise specified, all measurements are expressed in mm.

7.1 Preliminary checks

Before beginning the installation, make sure there is room for pedestrians to pass by, and disconnect the mains power supply to avoid any injuries.

- Check the stability and weight of the door wing. Make sure it moves smoothly, without any friction (reinforce the frame if necessary).
- Any "door closers" must be removed or completely annulled.
- Once you have made the slits for the cables to pass through, check the edges and smooth them if they are sharp, as they could damage the cables.
- To improve the degree of safety and the protection against vandalism, install the automation access inside the building if possible.
- Make sure the ambient temperature falls within the parameters indicated in the "Technical specifications" paragraph.
- Before you begin the installation, make sure the mains power supply is not connected.
- Check that the door wings and wall are adequately reinforced in the fixing points.
- Unpack the automation and make sure both it and its components are in good condition.
- Check the door wings have been built with suitable materials, and that there are no sharp corners. Any protruding parts must not create potential hazards. Sharp glass edges must not come into contact with other glass parts. You are advised to use tempered or stratified glass.
- Make sure there is no risk of getting trapped between the moving parts and the adjacent fixed ones when the door is opening. The following distances are considered sufficiently safe to avoid trapping the body parts indicated:
 - for the fingers: more than 25mm or less than 8mm
 - for the head: more than 200mm
 - for the feet: more than 50mm
 - for the whole body: more than 500mm

Fixing requisites

Material	Minimum requisites for the wall profile
Steel	5mm (reinforce with threaded rivets if the thickness is less than this)
Aluminium	6mm (reinforce with threaded rivets if the thickness is less than this)
Reinforced concrete	min. 50mm from the lower side
Wood	50mm
Brick	Anchor plug min. M6X85 UPAT PSEA B10/25 - min. 50mm from the lower side

7.2 General information

The DAB205 automation for swing doors can use articulated or sliding arms to open the doors.

The door is closed by a spring system, combined with the force of the motor.

The spring is pre-tensioned at 360°.



Do not alter the pre-tensioning of the spring unless it is strictly necessary.

7.3 Installation examples

The DAB205 automation for swing doors can be installed on one swing door, on two swing doors, or on two swing doors with a double exit.

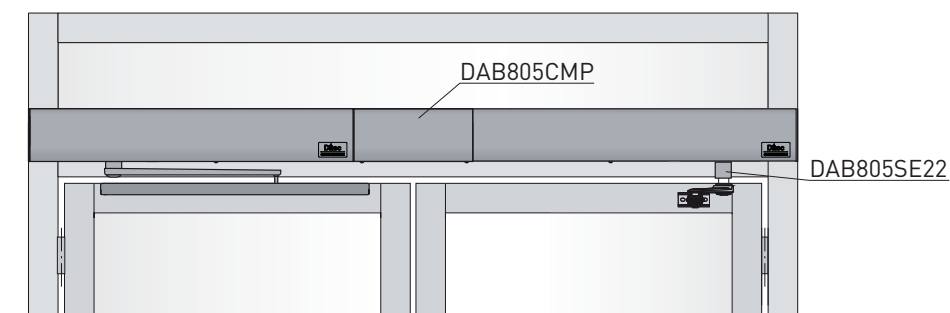
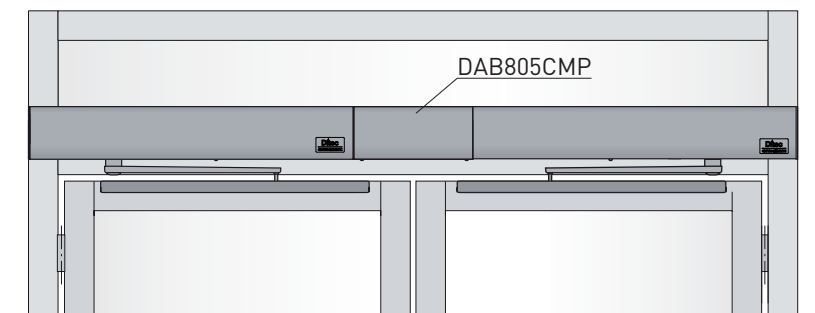
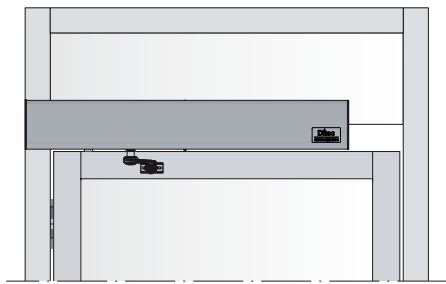

7.4 Removing the casing

Remove the casing [8] by loosening the screw [Z].

NB: the product label is in the position shown in the figure below.

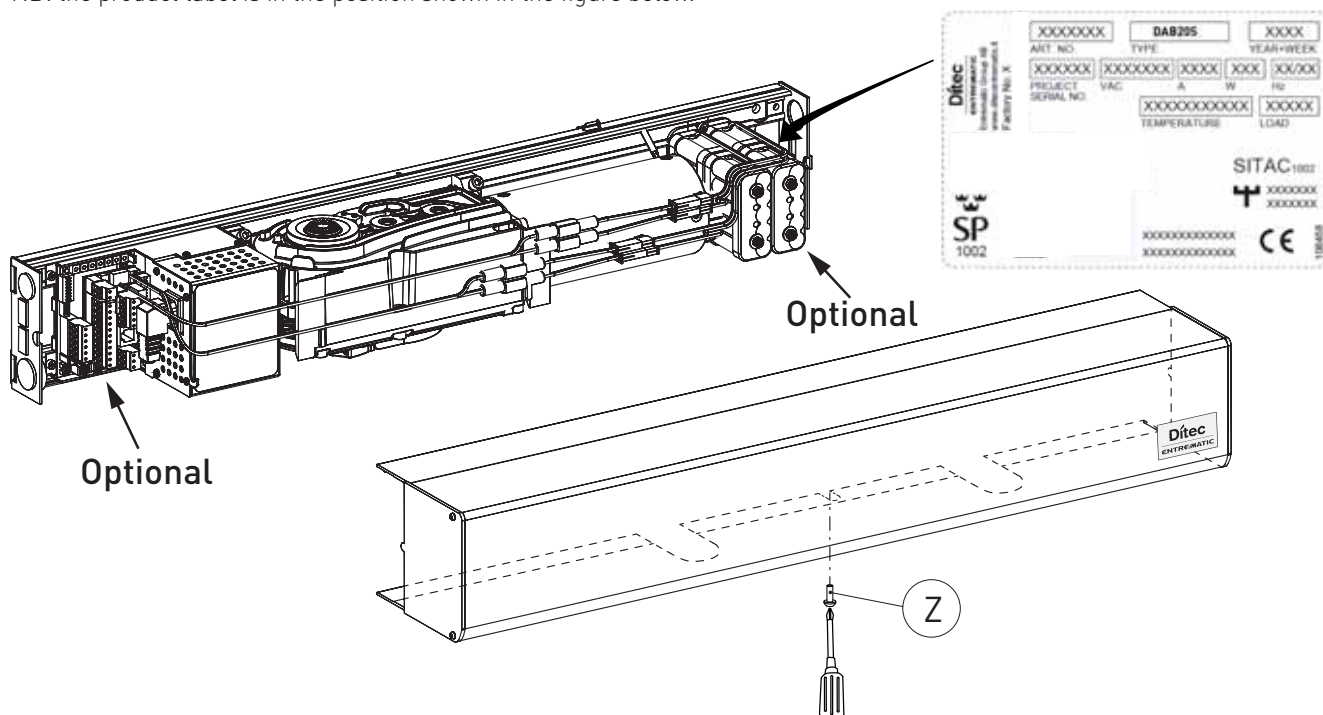

8. DAB805PSA2 automation with articulated arm

Use the articulated arm for doors that open outwards (as seen from the automation side).

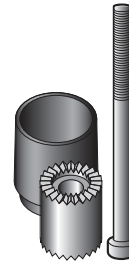
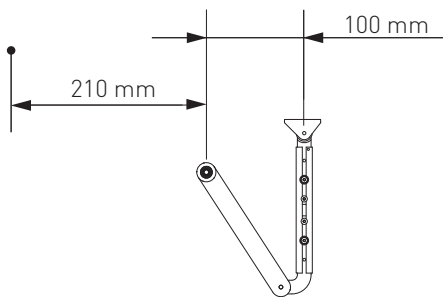
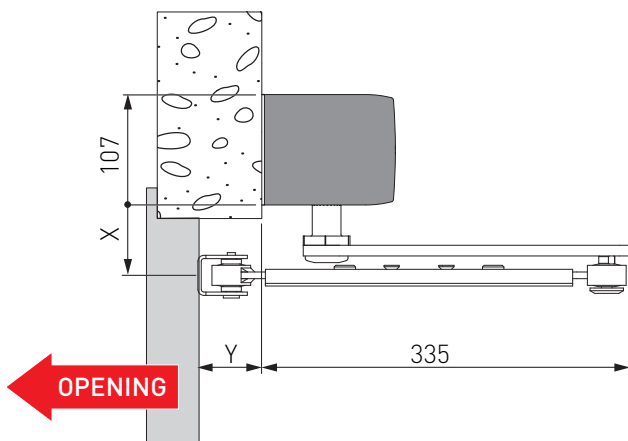

X	Shaft extension
48	/
68	DAB805SE22
98	DAB805SE52
118	DAB805SE72

Y	Arm extension	
0-100	/	
100-215	DAB805TFL	
215-305	DAB805TFS DAB805TKJ	

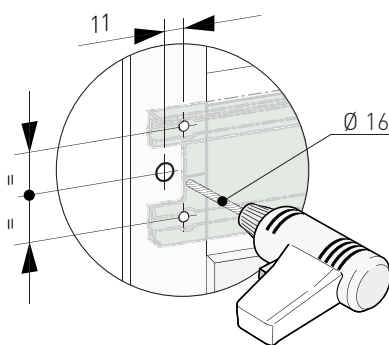

Before fixing the base plate [1], make holes for the cables to pass through.

8.1 Automation preparation and fastening

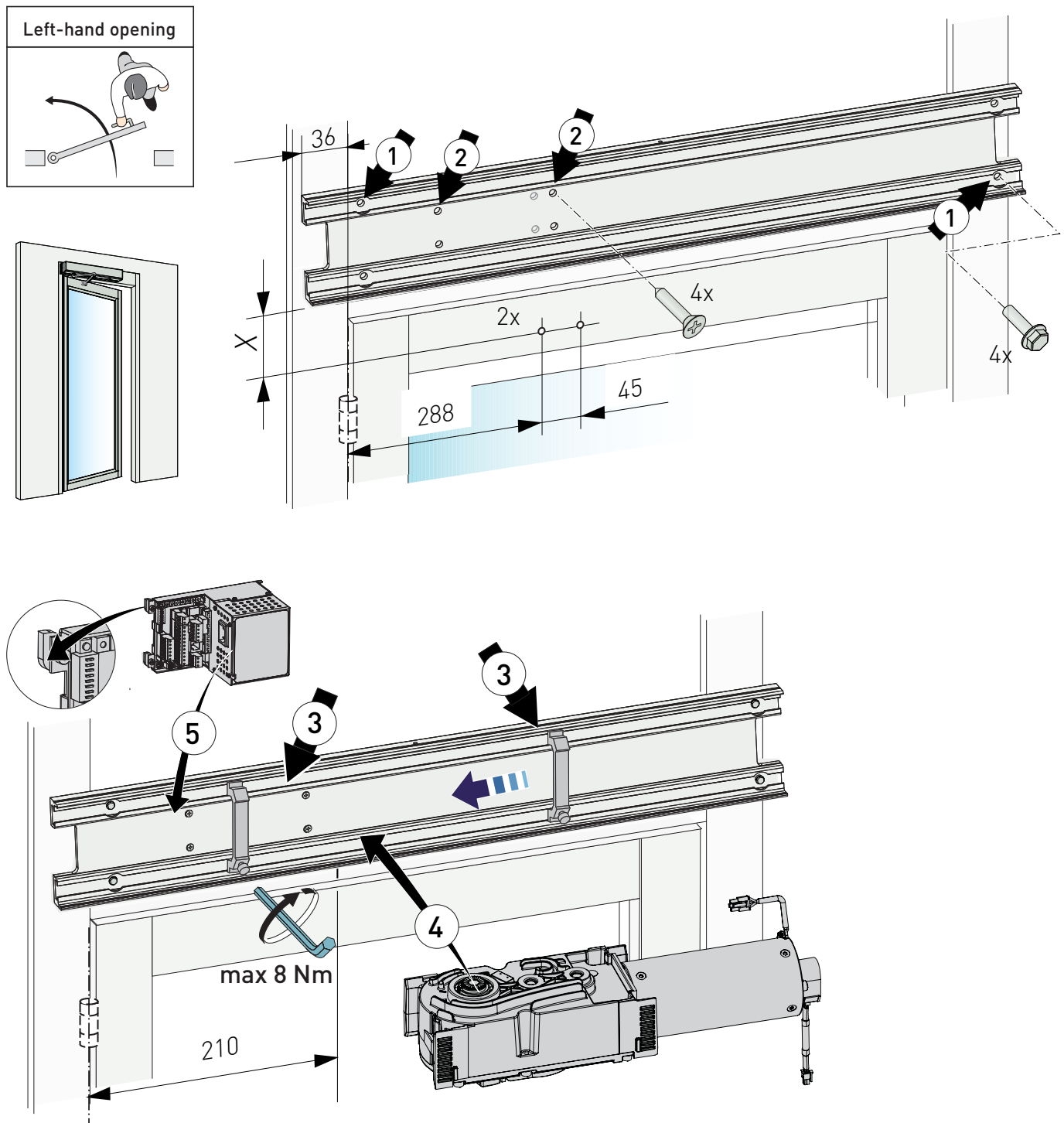

- Prepare the set-up for fixing the automation to the wall, respecting the measurements shown in the figures above (with reference to the hinge axis).
- Drill a hole in the door wing, in line with the fixing for the articulated arm.
- If necessary, use the DAB805SE22/SE52/SE72 extensions to increase the X measurement between the automation and the arm fixing points.
- Fix the gearmotor components, control panel and batteries (if used) on the base plate, as shown in the figure above.

i Respect the measurement between the hinge and the gearmotor shaft output [C], as shown in the figure.

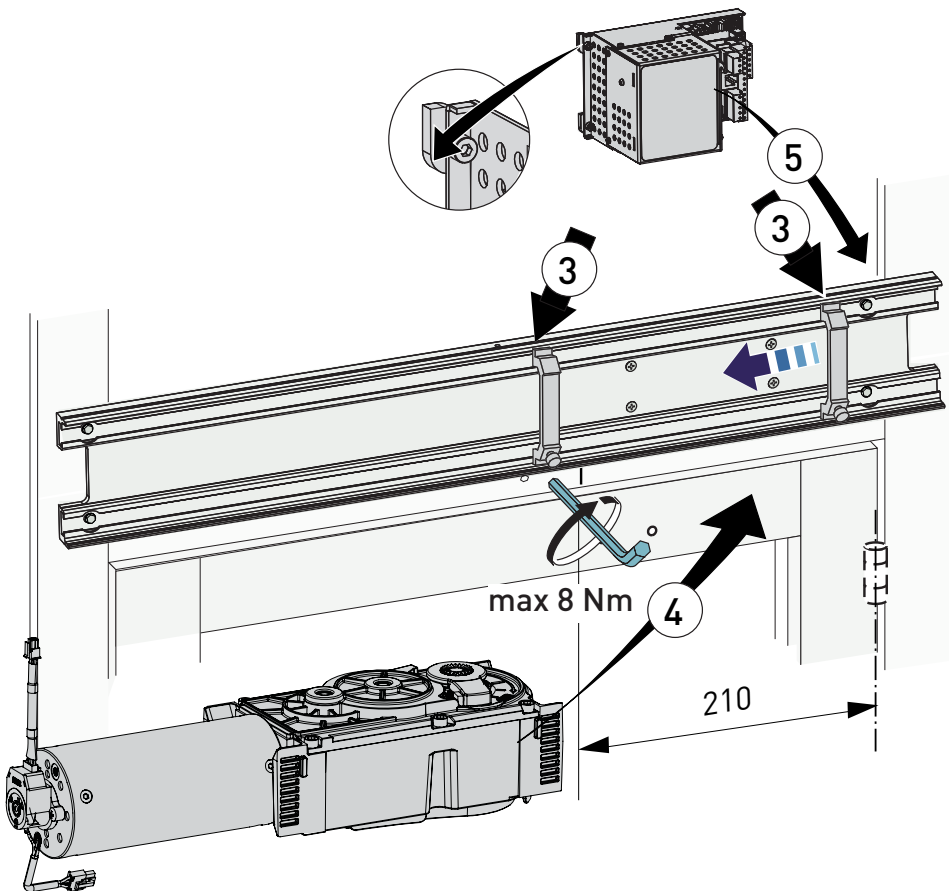
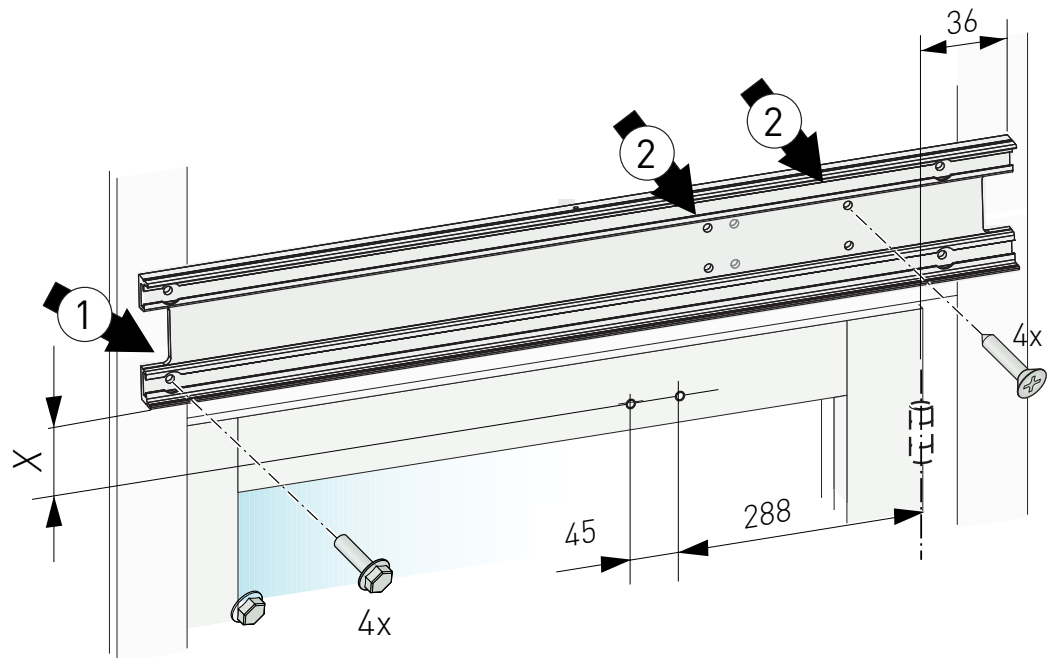
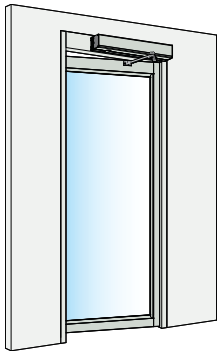
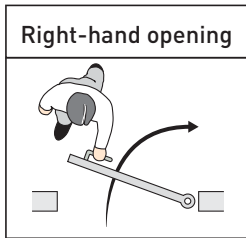

- Prepare the set-up for fixing the automation to the wall, respecting the measurements shown in the figures above (with reference to the hinge axis).
- Drill a hole in the door wing, in line with the fixing for the articulated arm.
- If necessary, use the DAB805SE22/SE52/SE72 extensions to increase the X measurement between the automation and the arm fixing points.
- Fix the gearmotor components, control panel and batteries (if used) on the base plate, as shown in the figure above.



Respect the measurement between the hinge and the gearmotor shaft output [C], as shown in the figure.

8.2 Fixing the arm

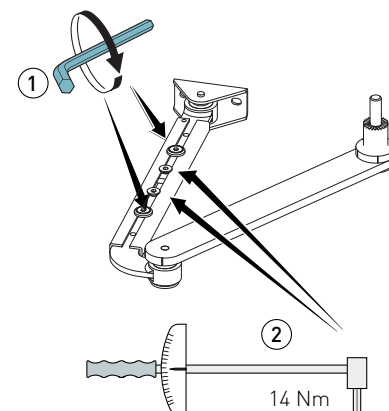
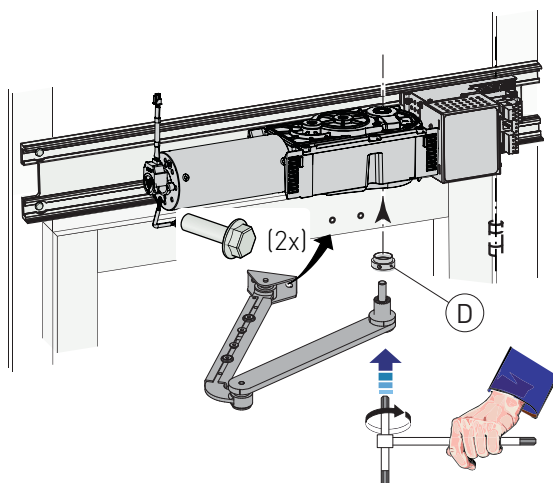
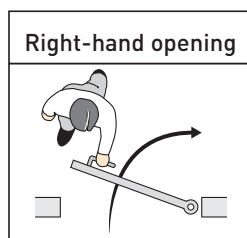
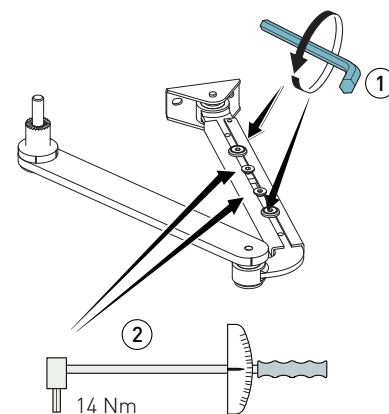
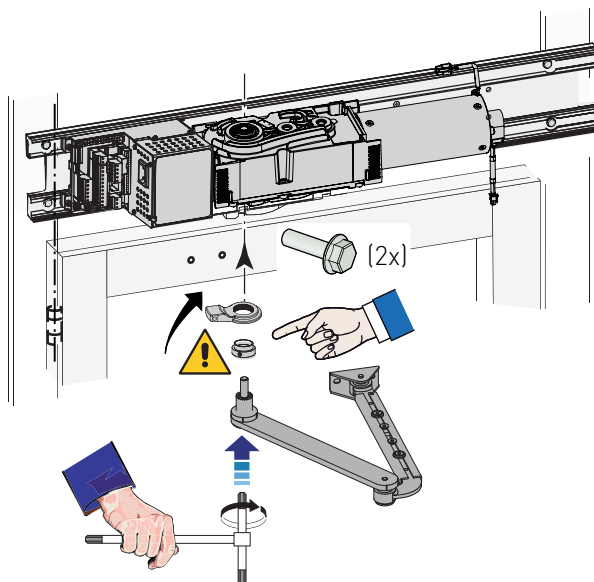
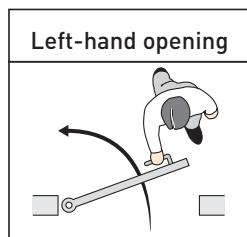
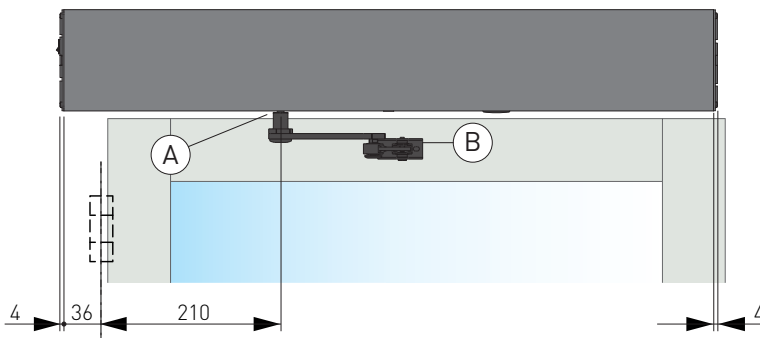
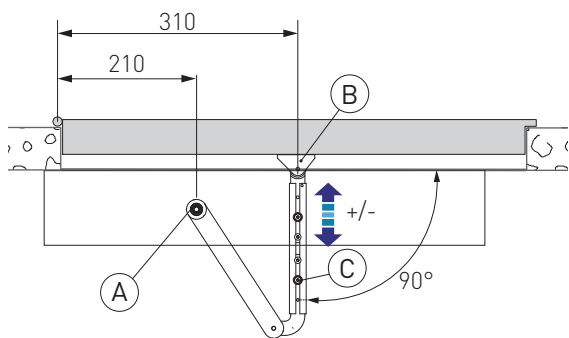

Place the stop ring [D] on the right opening as well, to cover the remaining space between the cover and the arm.

- Move the door manually to check it opens and closes correctly, without any friction.
- With the door closed, fix the arm to the arm support [A] on the automation.
- Fix the bracket [B] to the door wing, forming an angle of 90°. If necessary, lengthen (using the arm lengthening kit) or shorten the arm [C].

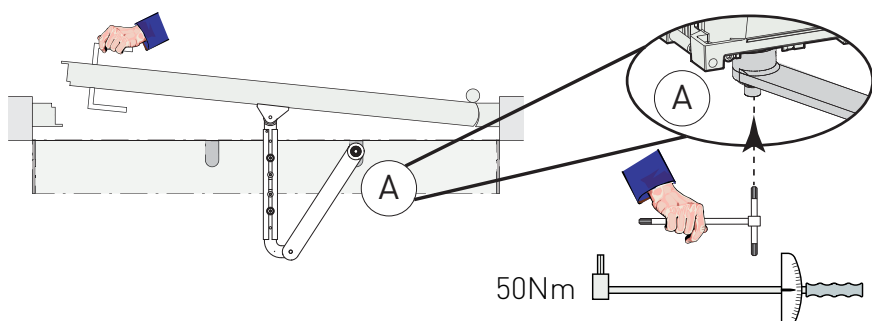

NB: open the door slightly and tighten the screw of the arm support seat [A] at 50 Nm (as shown in the figure). If a torque wrench is not available, use a hexagon wrench of the type shown in the figure, gripping it on the long side and tightening very firmly.

9. Automation with sliding arm DAB805PLA2

Use the sliding arm for doors that open inwards (as seen from the automation side).

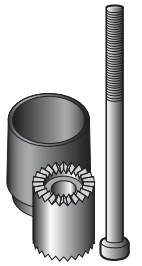
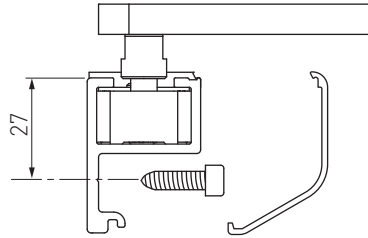
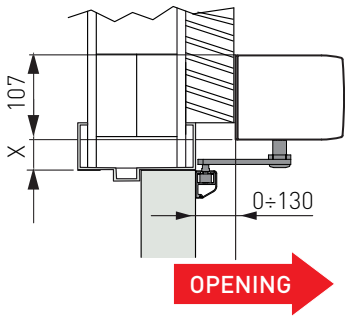

X	Shaft extension
46	/
66	DAB805SE22
96	DAB805SE52
116	DAB805SE72

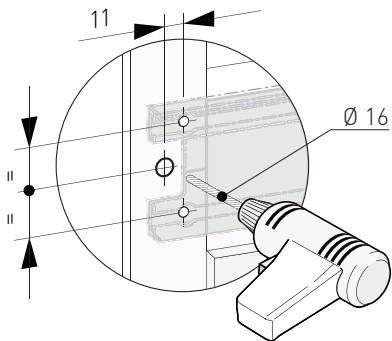

Before fixing the base plate [1], make holes for the cables to pass through.

9.1 Automation preparation and fastening

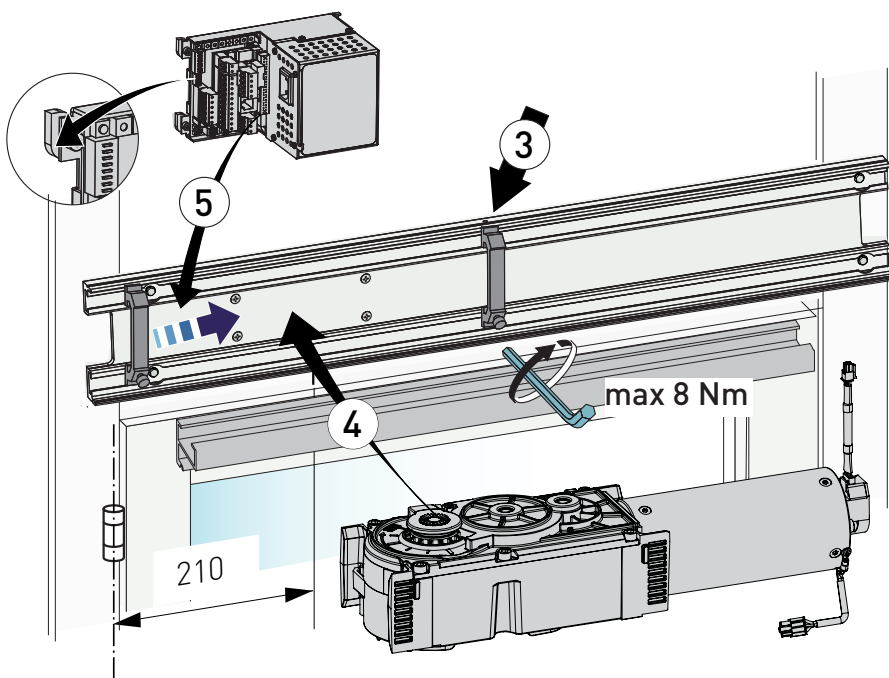
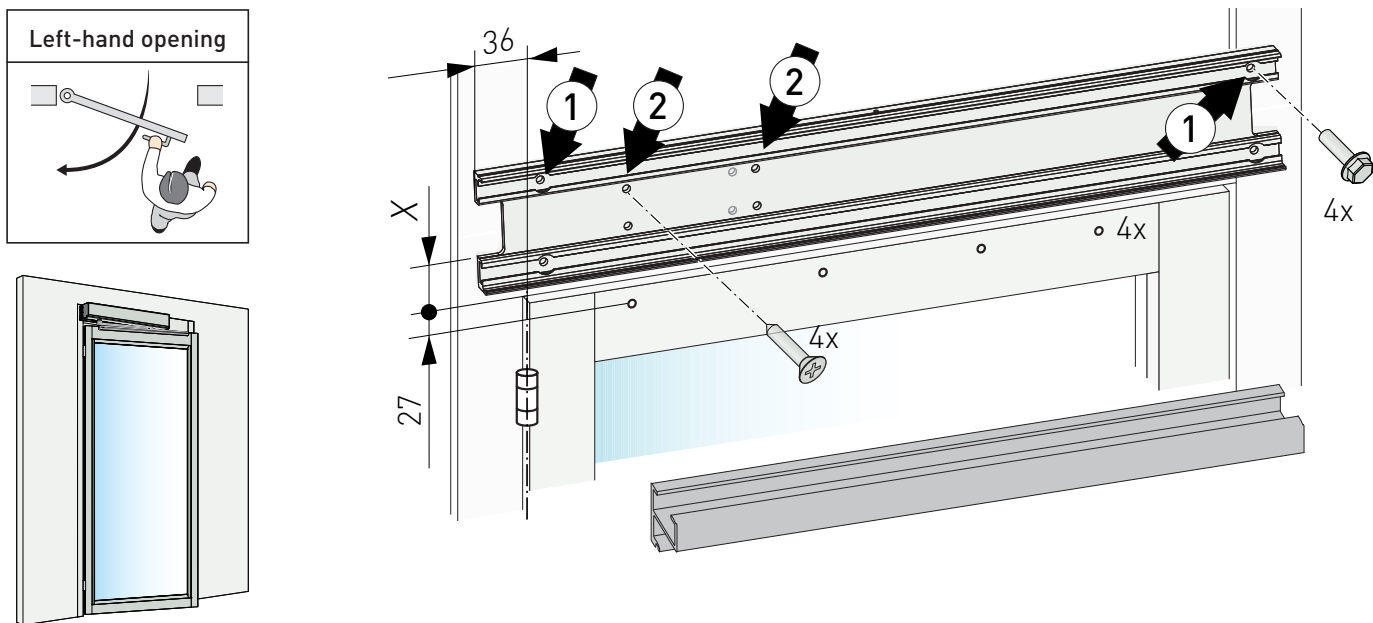

- Prepare the set-up for fixing the automation to the wall, respecting the measurements shown in the figures above (with reference to the hinge axis).
- If necessary, use the DAB805SE22/SE52/SE72 extensions to increase the X measurement between the automation and the arm fixing points.
- Drill a hole in the door wing, in line with the fixing for the sliding arm guide. Prepare at least four fixing points.
- Fix the slide guide to the door wing. If necessary, cut off the excess part of the guide.
- Fix the gearmotor components, control panel and batteries (if used) on the base plate, as shown in the figure above.



Respect the measurement between the hinge and the gearmotor shaft output [C], as shown in the figure.

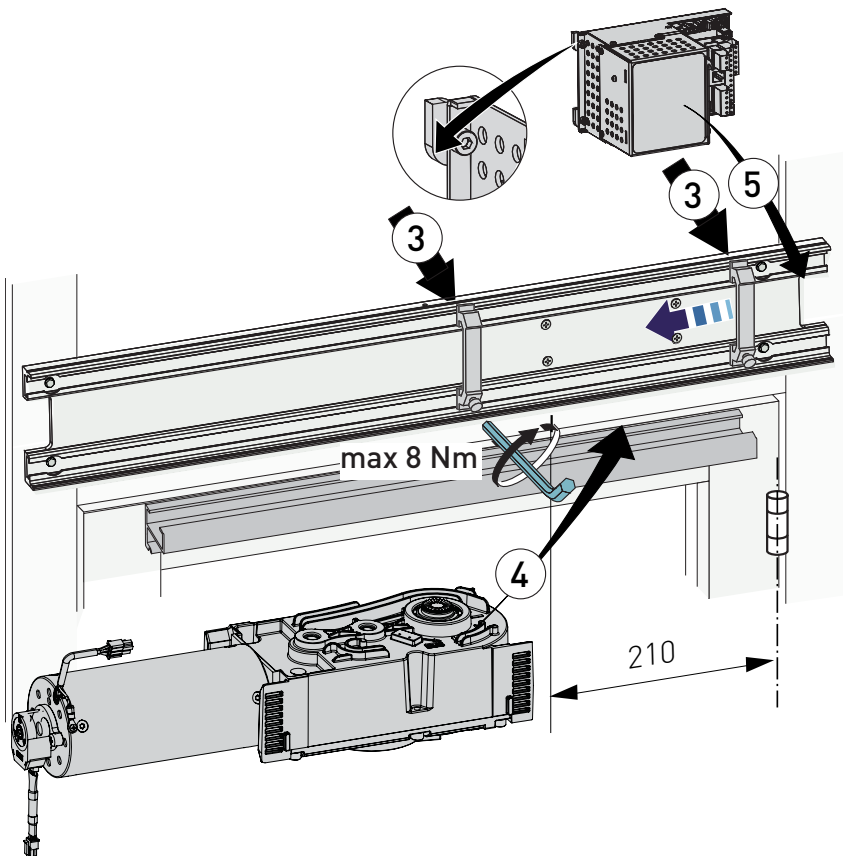
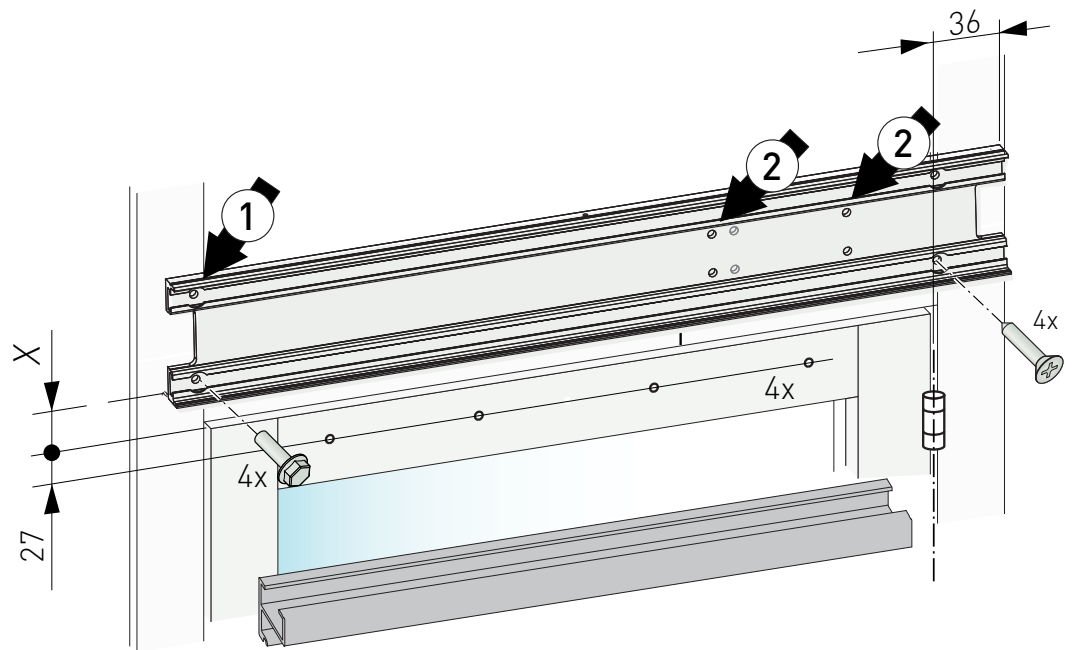
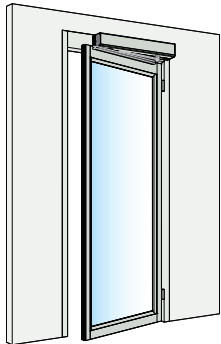
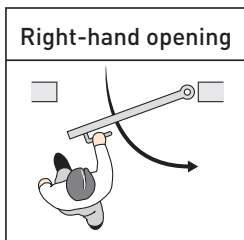

- Prepare the set-up for fixing the automation to the wall, respecting the measurements shown in the figures above (with reference to the hinge axis).
- If necessary, use the DAB805SE22/SE52/SE72 extensions to increase the X measurement between the automation and the arm fixing points.
- Drill a hole in the door wing, in line with the fixing for the sliding arm guide. Prepare at least four fixing points.
- Fix the slide guide to the door wing. If necessary, cut off the excess part of the guide.
- Fix the gearmotor components, control panel and batteries (if used) on the base plate, as shown in the figure above.



Respect the measurement between the hinge and the gearmotor shaft output [C], as shown in the figure.

9.2 Fixing the sliding arm

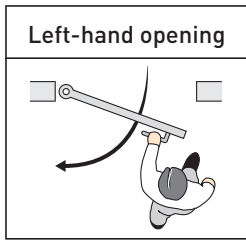

Place the stop ring [D] on the left opening as well, to cover the remaining space between the cover and the arm.

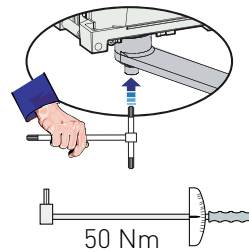
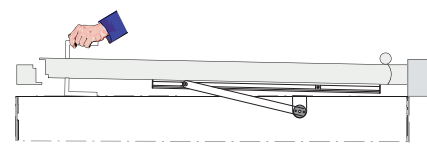
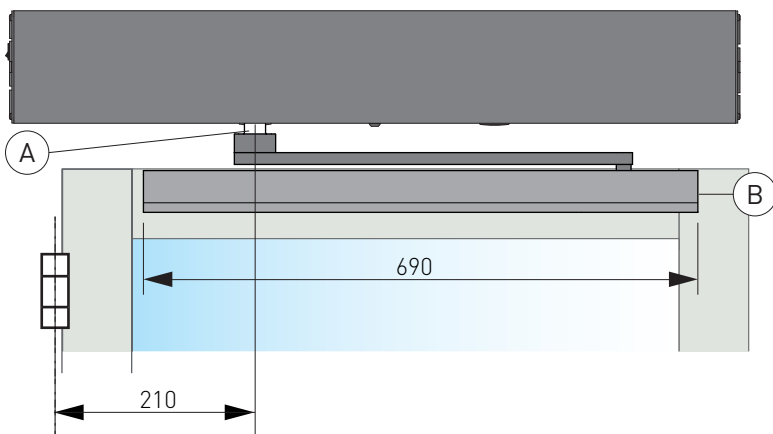
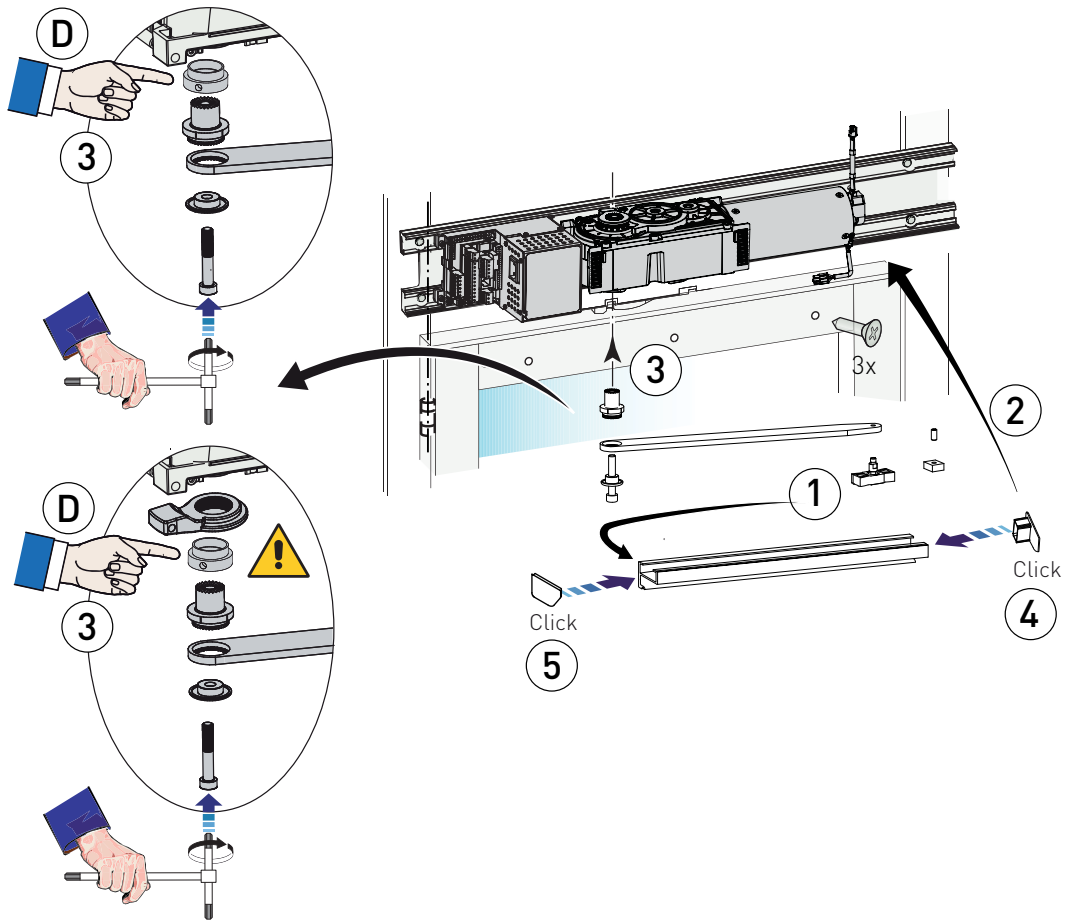
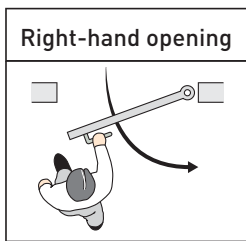

- Move the door manually to check it opens and closes correctly, without any friction.
 - With the door closed, fix the arm to the arm support [A] on the automation.
- NB: open the door slightly and tighten the screw of the arm support seat [A], as shown in the figure.

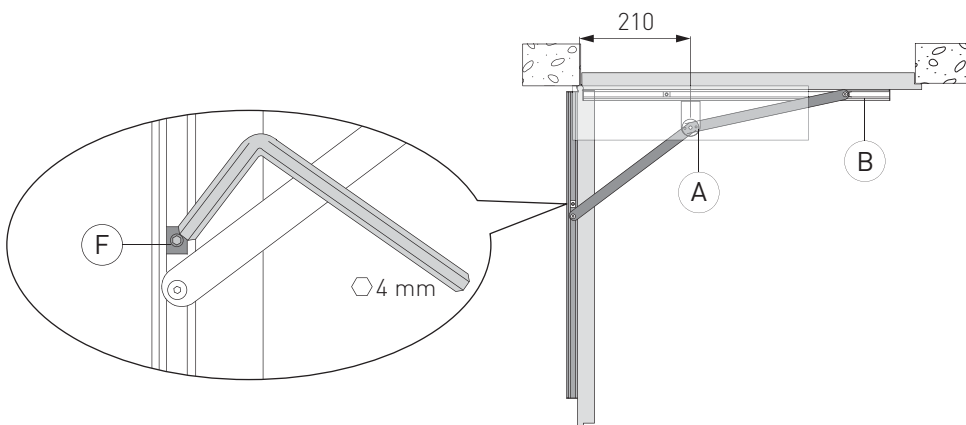

NB: open the door slightly and tighten the screw of the arm support seat [A] at 50 Nm (as shown in the figure). If a torque wrench is not available, use a hexagon wrench of the type shown in the figure, gripping it on the long side and tightening very firmly.

- Fully open the door and fix the open end stop to the slide guide, a few millimetres beyond the end of the stroke of the sliding arm.

10. Connecting to the electricity supply

Disconnect the mains power supply before making the electrical connections.

Before connecting the power supply, make sure the plate data correspond to that of the mains power supply.

An omnipolar disconnection switch with a contact opening distance of at least 3mm must be fitted on the mains supply.

Position the switch or electrical socket in a place that can be easily accessed by the operator.

Check there is an adequate residual current circuit breaker and overcurrent cut-out upstream of the electrical system.

In the section outside the automation, the connection to the mains power supply must be via an independent channel separate from the connections to the control and safety devices.

Make sure there are no sharp edges that may damage the power supply cable.

If the cables are damaged, they must be replaced to avoid any risk of danger.

Apply the supplied cable fasteners [E] as shown in the figure.

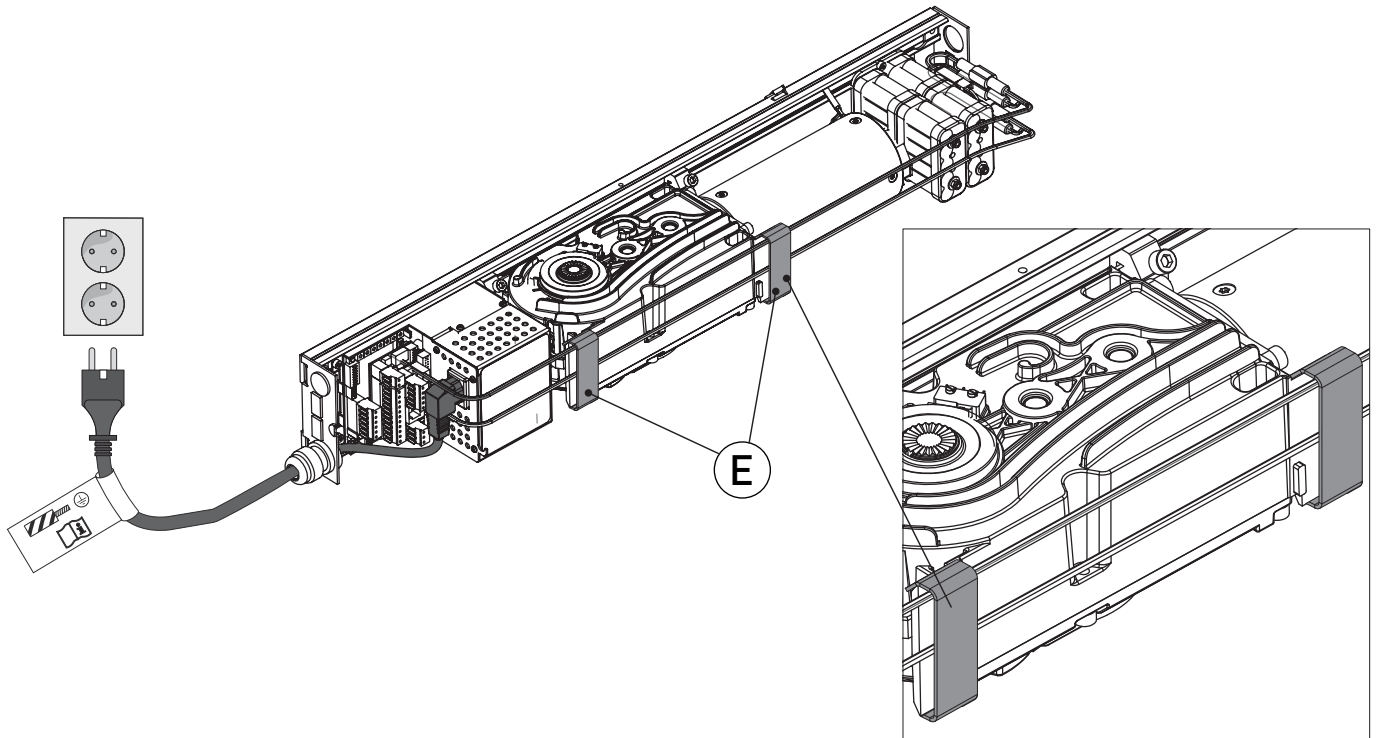

11. Starting up the door

Place the door in the closed position.



Rotate the SPTE trimmer on the control panel to 0° (if it is not already in this position).

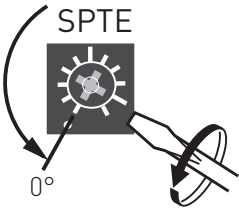

Turn on the power supply.

Gradually rotating the SPTE trimmer clockwise, the door opens electrically. Slowly bring it to the required open position, plus about 15mm.

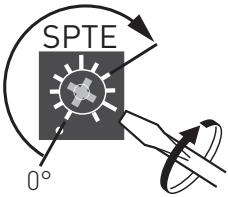

When the door stop is on the upper part of the gearmotor, raise it and position it in the groove, as close as possible to the open limit switch.

If necessary, make a fine adjustment with the screw on the open limit switch.

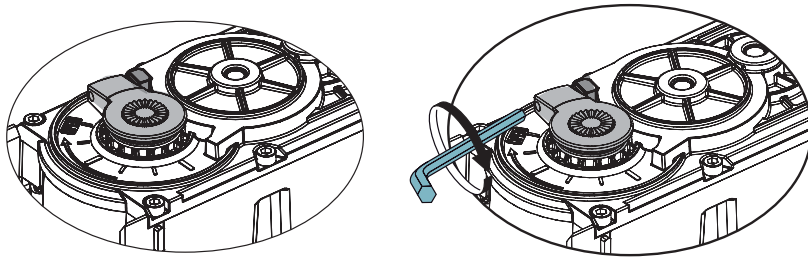

When the door stop is on the lower part of the gearmotor, loosen the door stop ring and the door stop itself. Insert the door stop in the groove, as close as possible to the open limit switch. Replace the door stop ring.

If necessary, make a fine adjustment with the screw on the open limit switch.

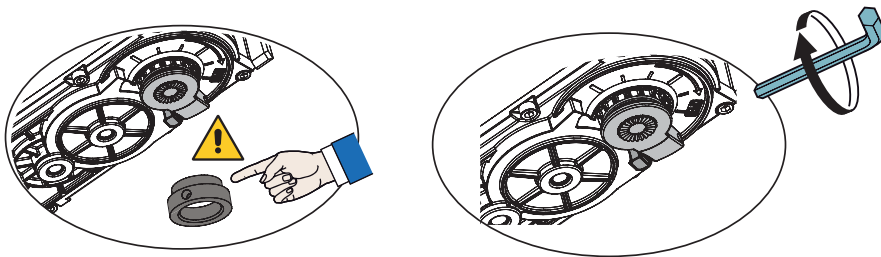

Close the door by rotating the SPTE trimmer to 0°.

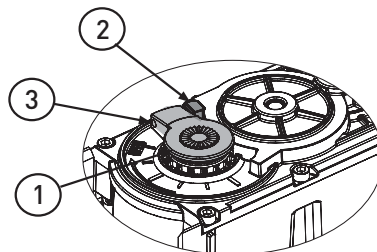
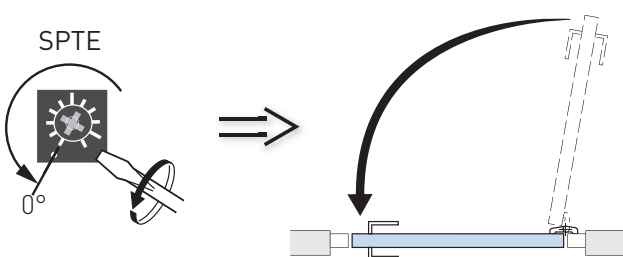

- 1- Door stop
- 2- Open limit switch
- 3- Limit switch adjustment screw

12. Electrical connections DAB205CU

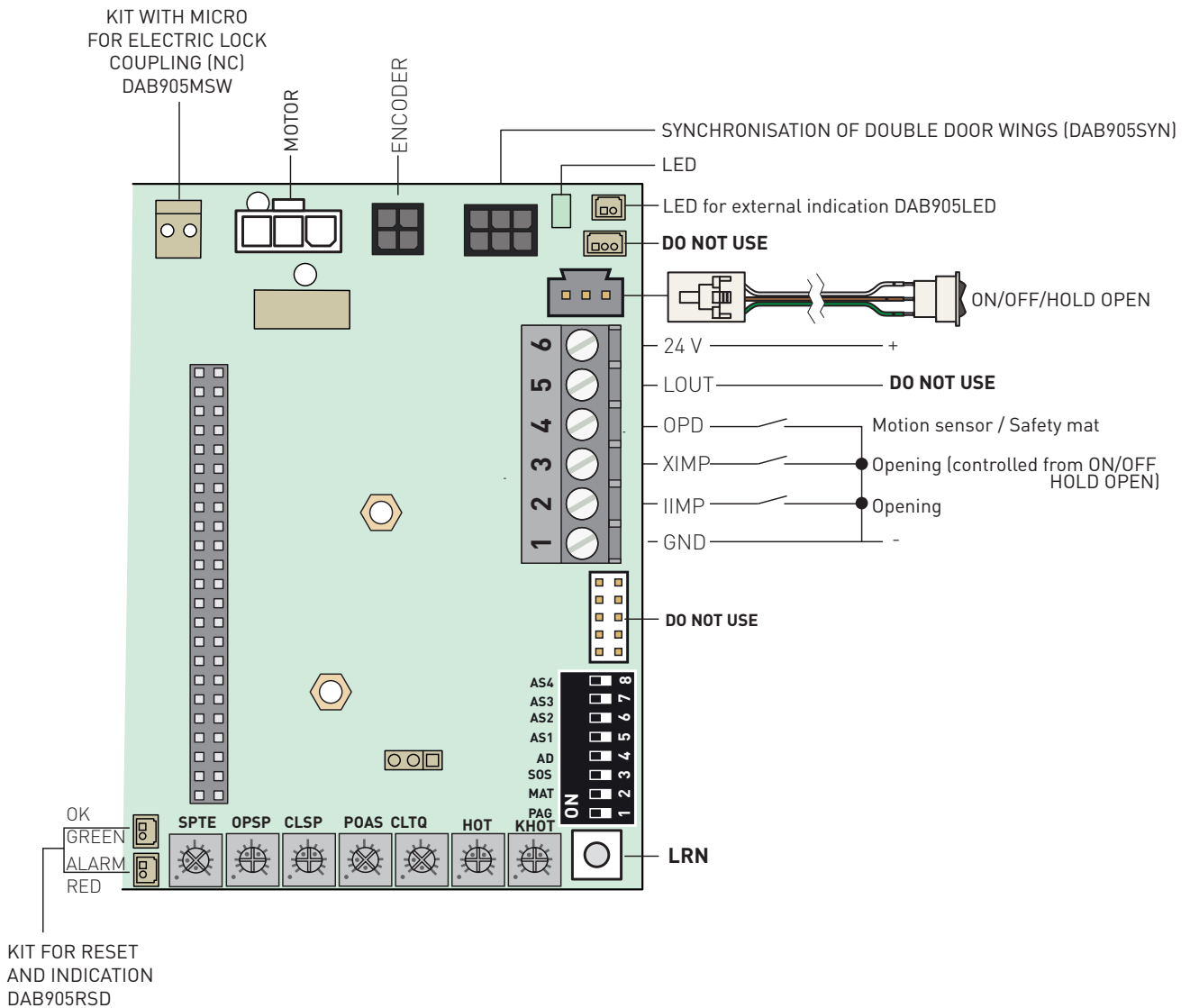

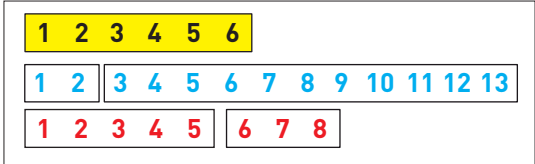

i Fix the label to the terminal board, taking care to apply it in the correct direction (see the figure above).









Optional extension units can be connected to the DAB205CU control panel: the DAB905ESE extension unit, or the DAB905ESA one, or both, depending on the required functions.

12.1 Commands

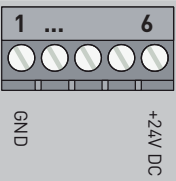
Contact	Function / Accessory	Description
1-2 GND-IIMP	NO OPENING - INNER SIDE	Contact closure activates the opening operation. The contact is always active if the ON-OFF-HOLD OPEN switch is present. The contact is controlled by the COM400MHB/MKB function selector switch (if present).
1-3 GND-XIMP	NO OPENING - OUTER SIDE, MANAGED BY THE ON-OFF-HOLD SWITCH	Contact closure activates the opening operation. The contact is only active if the ON-OFF-HOLD OPEN switch is present. DO NOT USE contact 1-3 or the ON-OFF-HOLD OPEN switch if the COM400MHB/MKB function selector switch is installed.
1-4 GND-OPD	NO Overhead presence detector (OPD), frame mounted	Overhead presence detector (OPD), frame mounted When an OPD sensor is mounted on the frame or operator cover just above the swing side of the door, it will—when activated—either keep the door open or closed. The sensor is not active during opening and closing. <ul style="list-style-type: none"> • a closed door will not open, if the OPD detects activity in the field. • an open door will not close, if the OPD detects activity in the field. • during opening, the door will continue to open, even if the OPD detects activity in the field. • during closing, the door will continue to close, even if the OPD detects activity in the field. • the OPD is not active in program mode OFF, manually opened door or during battery operation (Power Save Mode).
1-5 GND-LOUT	DO NOT USE	

Contact	Function / Accessory	Description
		<p>Automatic self-learning. When the door is started up, and on every spring tensioning variation, CLTQ trimmer variation, replacement of the extension units [DAB905ESE-DAB905ESA] or replacement of the electric lock / electric strike, it is necessary to perform an automatic self-learning operation.</p>
		<p> Make sure the door is fully closed. Move away from the door as soon as you have pressed the LRN button. The door has no safety settings during the automatic self-learning procedure. The door could suddenly slam shut.</p>
LRN		<p>By pressing the LRN button, the door launches an opening/closing operation for the automatic self-learning of the positions and of the opening/closing stops.</p>
		<p> DO NOT intervene during the self-learning procedure.</p>
		<p>During the closure phase, the spring pushes the door to acquire the door wing weight.</p> <p>By pressing the LRN button once, the door will open after 2 seconds. Press the LRN button twice to open the door immediately.</p> <p>In the case of double doors, the automatic self-learning operation must be carried out first on the MASTER door and then on the SLAVE door. The doors can be configured separately before connecting them with the synchronisation cable. In the case of door wing overlap and separate configurations, the MASTER door must be kept open until the SLAVE door has completed its own self-learning procedure.</p>

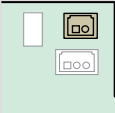
12.2 Outputs and accessories



Output	Description						
	<p>Output for the power supply to the accessories 24V = 700 mA max. NB: the maximum absorption of 700 mA corresponds to the sum of all the accessories installed.</p>						
<p>KICK</p> 	<p>Connection of the kit with micro for electric lock / electric strike coupling DAB905MSW (120 V 5A). When the coupling micro is activated and mains voltage is absent, the door increases its force/speed to ensure correct closure on the electric lock or electric strike. Remove the jumper from the control panel, and connect the electric lock / electric strike coupling micro.</p>						
<p>MOTOR</p> 	<p>Motor connection</p>						
<p>ENCODER</p> 	<p>Encoder connection</p>						
<p>SYNC</p> 	<p>Connection for cable for synchronisation between two swing doors (2000mm). For details about the operation, refer to the "SYNCHRONISED DOORS" chapter.</p>						
<p>LED</p> 	<p>External indicator (1000mm) Connect the DAB905LED for the visual signalling of the alarm diagnostics. If the LED is ON, it indicates that the power supply is turned on. If the LED is OFF, it indicates that the power supply is not turned on. If the LED flashes, see the "Alarms" paragraph. To secure, use a Ø4.5mm hole (for example, on the automation head).</p>						
<p>ON/OFF/HOLD</p> 	<table border="1"> <tr> <td>ON</td> <td>The IIMP and XIMP opening contacts are enabled.</td> </tr> <tr> <td>OFF</td> <td>The XIMP opening contact is excluded.</td> </tr> <tr> <td>HOLD OPEN</td> <td>Door open.</td> </tr> </table>	ON	The IIMP and XIMP opening contacts are enabled.	OFF	The XIMP opening contact is excluded.	HOLD OPEN	Door open.
ON	The IIMP and XIMP opening contacts are enabled.						
OFF	The XIMP opening contact is excluded.						
HOLD OPEN	Door open.						
<p>INDICATION AND RESET DEVICE</p> 	<p>Connection of the DAB905RSD indication and reset device (for fire barriers only). The GREEN LED indicates normal automation operation. The RED LED indicates an alarm following the activation of the KILL contact (1 flash every 10 s).</p>						



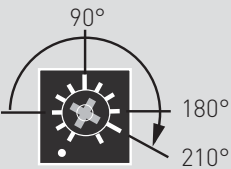







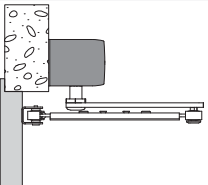

12.3.Adjustments

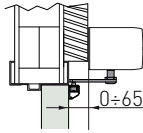
Trimmer

Trimmer	Description
SPTE 	<p>Door start-up The SPTE trimmer is used to make adjustments for the acquisition of the opening/closing stops when the door starts up.</p>
	<p>Spring tension adjustment The spring pre-tensioning is factory-set at 360°. If necessary, it can be increased / decreased by following the procedure below.</p> <p>i The maximum pre-tensioning of the spring is 720°. A greater tension could damage the spring or overheat the motor.</p> <p>Make sure the mains power supply is connected, and that the CLTQ and POAS trimmers are set at minimum. To reduce/increase the pre-tensioning:</p> <ul style="list-style-type: none"> • Loosen and remove the door stop • Rotate the trimmer clockwise until the door opens at 45° • Loosen the fixing screw of the actuation arm • Move the door towards the open position to reduce the spring tension • Move the door towards the closed position to increase the spring tension • Tighten the fixing screw of the actuation arm • Rotate the trimmer to minimum • Open the door to the required open position plus about 15mm, by rotating the trimmer clockwise • Fix the door stop as close as possible to the open door stop • Rotate the trimmer to minimum • Press the LRN button to begin the door self-learning procedure
OPSP	<p>Adjustment of the opening speed time (from 2.5 to 12 s) Rotate the trimmer clockwise to increase the opening speed. NB: in installations with heavy doors, the time increases.</p>
CLSP	<p>Adjustment of the closing speed time (from 4 to 12 s) Rotate the trimmer anticlockwise to reduce the closing speed. NB: in installations with heavy doors, the time increases.</p>
POAS	<p>Adjustment of the servo-assisted movement during the manual opening of the door. With the trimmer at its minimum, the door is not servo-assisted. By rotating the trimmer clockwise, the motor increases the servo-assistance when the door is opened manually. The range of the POAS is depending on the spring pre-tension.</p>
CLTQ	<p>Closing force adjustment With the trimmer at its minimum, the door closes with the force of the spring. By rotating the trimmer clockwise, the motor increases the closing force. Increase the closing force on doors installed in environments with different pressure levels or subject to strong gusts of wind. Extended closing torque will be reduced to zero:</p> <ul style="list-style-type: none"> • If the door mounted sensor is activated in closed position or during closing (even if manually opened). Does not apply to program select DOOR CLOSE. • Also, extended closing torque will be canceled after the first closing by KILL, in all program selections.
HOT	<p>Adjustment of the automatic closing time (from 1.5 to 30 s) Adjust the time that passes between the end of the opening operation and the start of the closing operation. The count begins with the door fully open.</p>
KHOT	<p>Adjustment of the automatic closing time following an open command from the KEY contact on DAB905ESE (from 1.5 s to 30 s) Adjust the time that passes between the end of the opening operation and the start of the closing operation. The count begins with the door fully open.</p>

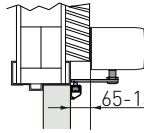
Dip-switches



DIP	Description	OFF 	ON 
DIP1 - PAG	Push & Go The manual pushing of the door activates an automatic opening operation. When the door is closed, a closure thrust is maintained by the motor or the spring. "Push and Go" is not active in program selector setting DOOR CLOSED.	Disabled	Enabled NB: this function is not active when the function selector switch is on NIGHT.
DIP2 - MAT	DO NOT USE		
DIP3 - SOS	Obstacle during opening	Stall If an obstacle is detected during the opening operation, the door continues to push open and then closes after the time lapse set with the HOT trimmer.	Stop If an obstacle is detected during the opening operation, the door stops its movement and closes after 2 s.
DIP4 - AD	DO NOT USE		
DIP5 - AS1	SELECTION OF THE TYPE OF ARM REFER TO THE TABLE BELOW		
DIP6 - AS2			
DIP7 - AS3			
DIP8 - AS4			

Arm DAB805PSA2	DIP5	DIP6	DIP7	DIP8	Arm DAB805PLA2	DIP5	DIP6	DIP7	DIP8	Arm DAB805PLA2	DIP5	DIP6	DIP7	DIP8
														



Launch the SELF-LEARNING procedure (see paragraph 12.1) after every variation in the arm type selection.

Signals

	ON 	OFF 	FLASHING 
LED	Normal operation	No mains power supply	Alarm (see the alarms table)

12.4 Alarms



An external alarm signalling LED can be connected (DAB905LED).

LED	CAUSE	SOLUTION
(1) (every 10 s)	KILL command active	Enable a KILL reset, or a KILL switch reset, or a fire alarm reset
(1) (every 2 s)	External short circuit on 24V DC. Incorrect sensor detection	Check for short-circuiting or a damaged sensor
(2)	Faulty battery	Replace the battery . If battery monitoring is active it needs to be reset. See paragraph 17.2
(3)	Faulty control panel	Replace the control panel
(4)	Encoder error	Check the encoder cable. Manually open and close the door, then check the automatic function. If the problem persists, replace the gearmotor.
(5)	Faulty blocking device	Check for short-circuiting in the blocking device Replace the blocking device
	Faulty DAB905ESE unit	Replace the DAB905ESE unit
(6)	Synchronisation cable not connected, or faulty (parallel doors only)	Connect the cable
		Replace the cable
(7)	SLAVE control panel faulty (parallel doors only)	Check the frequency of the flashes on the SLAVE LED, and adopt the necessary measures on the basis of this table
(8)	Overheated motor	Wait for the motor to cool down
(9)	Door blocked and repetitive command	Activate and deactivate the command
(10)	Self-learning procedure failed, or request for a new self-learning procedure after modifications made to settings	Perform a new self-learning procedure. Check the settings

13. Pre-configured parameters

The DAB205 automation has 16 groups of pre-configured system-loaded parameters.

The group of parameters set in the factory corresponds to number 1.

To modify the group of parameters:

1. Disconnect the batteries (if installed).
2. Disconnect the mains power supply.
3. Press the LRN self-learning button, and keep it pressed.
4. Enable the power supply - the LED will light up Release the LRN self-learning button - the LED will switch off.
5. The LED flashes for a number of times corresponding to the number of the group of parameters (see the table).
6. Press the LRN button to pass to the next group of parameters after the set one. When you have reached the maximum limit of the parameters, you will restart from number 1.
7. Press the LRN button until you reach the required group of parameters.
8. Disconnect the mains power supply.
9. When the mains power supply is reconnected, the automation will use the new group of parameters.



SEE THE PARAMETERS TABLE ON PAGE 26

Parameter group	1 (factory setting)	2	3	4	5	6	7	8	9	10	11	12	13	14	15	16
Time of door open contact 3-5 ESE card (a)	15 min	endless	15 min	15 min	15 min	15 min	15 min	15 min	15 min	15 min	15 min	15 min	15 min	15 min	endless	endless
Battery use	Energy savings	Energy savings	Continuity	Energy savings	Energy savings	Energy savings	Energy savings	Energy savings	Energy savings	Continuity	Energy savings	Energy savings	Energy savings	Energy savings	Continuity	Continuity
Block mode with KILL command active	Blocked	Blocked	Blocked	Block managed by selector	Blocked	Blocked	Blocked	Blocked	Block managed by selector (*)	Blocked	Released	Released	Blocked	Released	Blocked	Blocked
Obstacle during closure (b)	Closure	Closure	Closure	Closure	Reversal	Closure	Closure	Closure	Closure	Reversal	Closure	Closure	Closure	Closure	Reversal	Reversal
Motion sensor installed on synchronised doors. (c)	Separate detection	Separate detection	Separate detection	Separate detection	Separate detection	Common detection (**)	Separate detection	Separate detection	Separate detection	Separate detection	Separate detection	Separate detection	Separate detection	Separate detection	Separate detection	Separate detection
Block attempt on closure (d)	Enabled	Enabled	Enabled	Enabled	Enabled	Enabled	Disabled	Enabled	Enabled	Enabled	Enabled	Enabled	Enabled	Enabled	Enabled	Enabled
O/C command opening/closing (e)	TWO-WAY mode	TWO-WAY mode	TWO-WAY mode	TWO-WAY mode	TWO-WAY mode	TWO-WAY mode	TWO-WAY mode	TWO-WAY / DOOR CLOSED / ONE-WAY mode	TWO-WAY mode	TWO-WAY mode	TWO-WAY mode	TWO-WAY mode	TWO-WAY mode	TWO-WAY mode	TWO-WAY / DOOR CLOSED / ONE-WAY mode	TWO-WAY / DOOR CLOSED / ONE-WAY mode
Configuration of emergency closure contact (KILL)	NO	NO	NO	NO	NO	NO	NO	NO	NC Monitored	NO	NO	NC Monitored	NC Monitored	NC Monitored	NO	NC Monitored
COM-NO-NC relay contact (ESA card) (d)	Error indication	Error indication	Error indication	Error indication	Error indication	Error indication	Error indication	Error indication	Error indication	Error indication	KILL output in parallel with other doors	KILL output in parallel with other doors	KILL output in parallel with other doors	Block connection with power supply other than 12/24V DC	Block connection with power supply other than 12/24V DC	Block connection with power supply other than 12/24V DC

NOTES:

- (*) The block is released during a KILL command in one-way opening mode.
- (a) If the door stays open following an O/C open command, after 15 min of inactivity the control panel will launch a closure command.
- (b) If set in "CLOSURE" mode, the automation will stop if an obstacle is detected.
If set in "REVERSAL" mode, the automation will re-open. It continues to attempt the closure operation until the obstacle is removed.
- (c) In the case of synchronised doors, the motion sensor can intervene independently on each door, or simultaneously.
- (**) Bear in mind that the use of Push and Go together with this parameter could cause interruptions to pedestrian access.
- (d) In parallel automations, this parameter will act on the SLAVE automation as set by the parameter group for the SLAVE door, without taking into consideration the configuration set on the MASTER door.
With parameters set on 1 (factory setting), if there is a problem with block coupling during the closure phase, the door will attempt to enable the coupling twice in automatic mode, then once more in manual mode.
This function can be disabled (see Parameter 7) and, in the parallel automations, the SLAVE door must be configured separately.
- (e) With the ON/OFF/HOLD switch, the O/C command is always active, except in the "HOLD - Door open" position.
With the program selector, the O/C command usually functions in TWO-WAY mode.
With Parameter 8 selected, the O/C command functions in TWO-WAY / ONE-WAY / DOOR CLOSED mode.

14. Door requisites for Low Energy use

The DAB205 automation is factory supplied with the Low Energy setting enabled. If necessary, adjust the OPSP and CLSP trimmers so that the opening and closing times are the same or longer than those indicated in the table in accordance with EN16005:2012 and ANSI 156.19 (the information in brackets refers to DIN 18650-2).

The table shows the minimum opening times for opening of up to 80° and the minimum closing times for openings from 90° to 10°.

		Door wing weight [kg]				
		50	60	70	80	90
Door wing length [mm]	750	3,0 s (3,0 s)	3,0 s (3,2 s)	3,0 s (3,2 s)	3,0 s (3,3 s)	3,5 s (3,5 s)
	850	3,0 s (3,1 s)	3,0 s (3,1 s)	3,5 s (3,2 s)	3,5 s (3,4 s)	4,0 s (3,6 s)
	1000	3,5 s (3,2 s)	3,5 s (3,4 s)	4,0 s (3,7 s)	4,0 s (4,0 s)	4,5 s (4,2 s)
	1200	4,0 s (3,8 s)	4,5 s (4,2 s)	4,5 s (4,5 s)	5,0 s (4,8 s)	5,5 s (5,1 s)

Or modify the classifications as shown in the table.

1. Disconnect the batteries (if installed).
2. Disconnect the mains power supply.
3. Press the LRN self-learning button, and keep it pressed. Enable the power supply.
4. The LED will light up .
5. Release the LRN self-learning button - the LED will switch off.
6. The LED flashes as many times as the classification number (see table).
7. Press the LRN button to pass to the next classification number after the set one.
8. Press the LRN button until you reach the required classification.
9. Disconnect the mains power supply.
10. When the mains power supply is reconnected, the automation will use the new setting.

CLASSIFICATION	1 - Maximum performance	2 - Low energy (factory setting)
Standard	/	In accordance with DIN18650-2 (EN16005:2012)
Opening speed	2.5-12 s	Automatic limit 1,69 J
Closing speed	4-12 s	Automatic limit 1,69 J

The maximum setting for the opening speed and closing speed is automatically limited to the value indicated in the table; consequently, the speed may only be reduced.



Launch the automatic self-learning procedure (LRN button) after every parameter setting modification.

15. Door requisites for use by disabled people

If the DAB205 automation is applied to doors used by disabled people, adjust the automatic closing time following an open command given by a KEY contact using the KHOT trimmer (from 1.5 s to 30 s).

16. Example of an application with a standard control panel

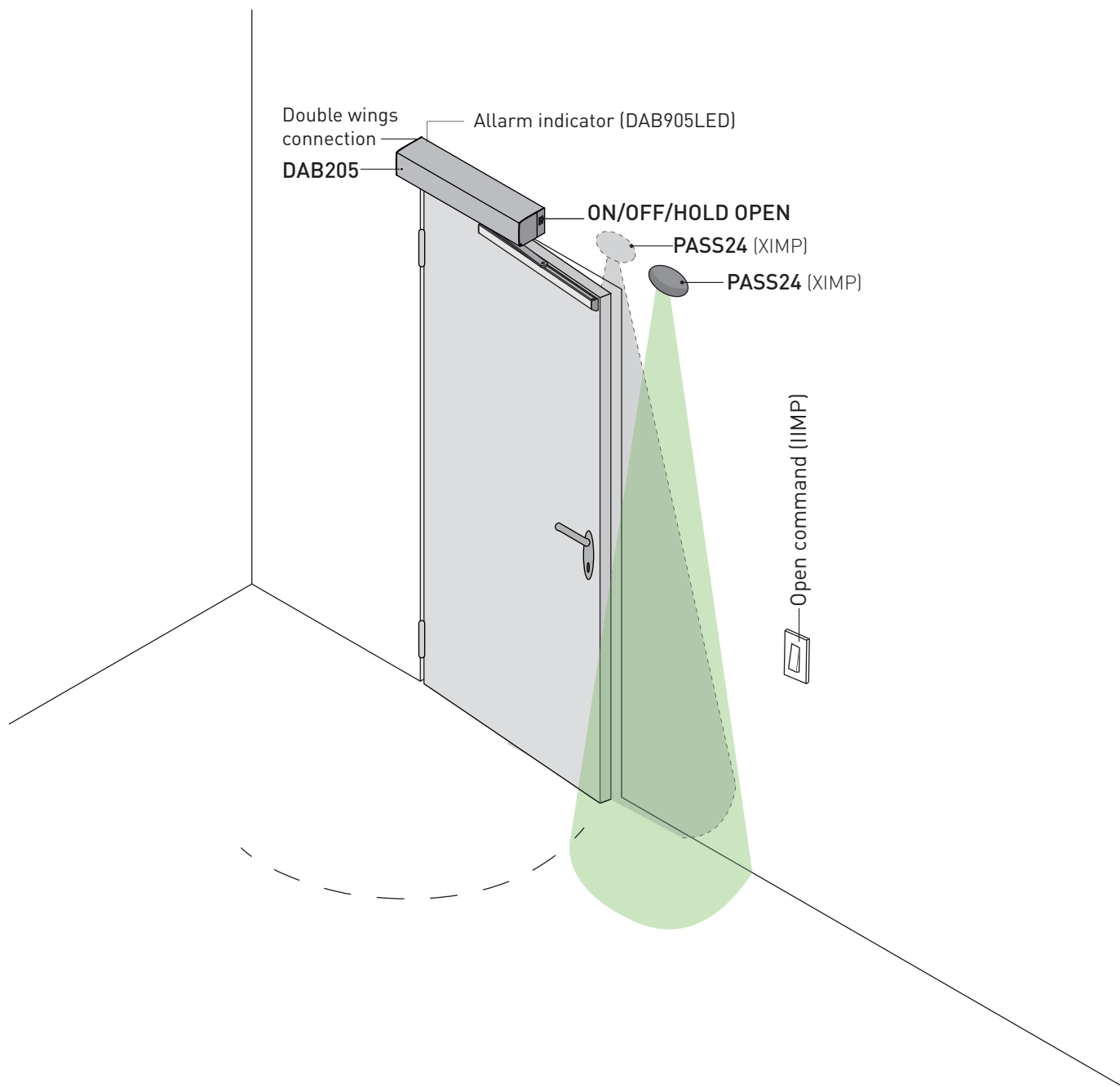

17. Extension unit DAB905ESE (optional)

There is a command extension card for managing the electric lock / electric strike, function selector, batteries, key selector switch and night-time closure.

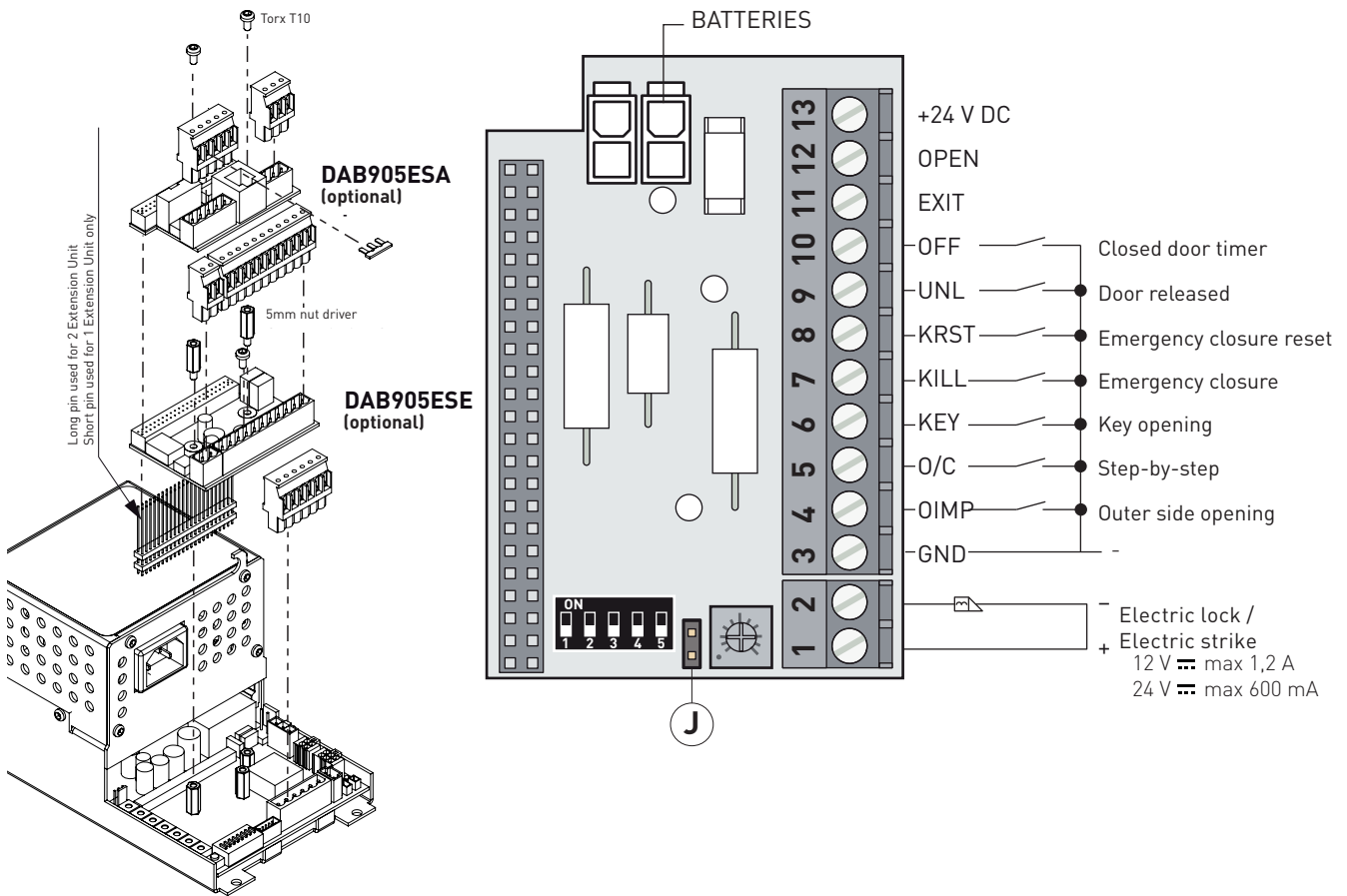

i Fix the label to the terminal board, taking care to apply it in the correct direction (see the figure above).

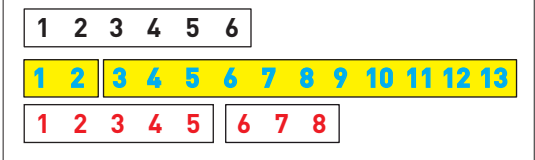

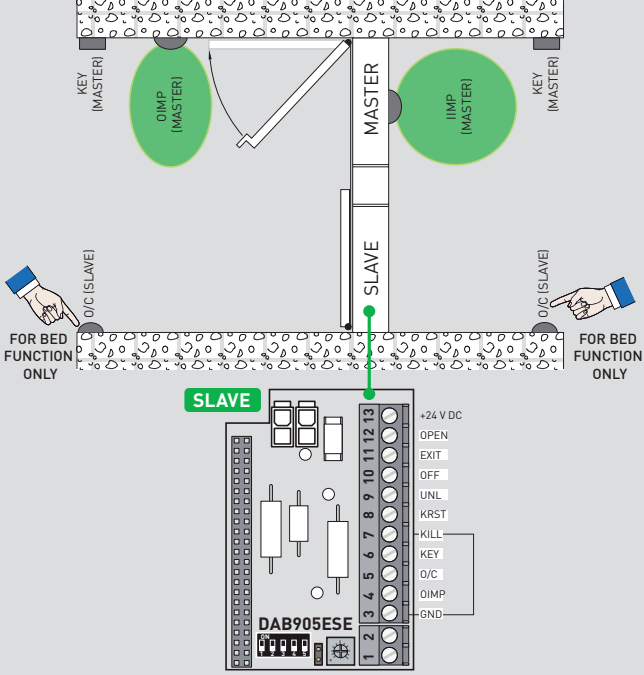

17.1 Commands

Contact		Function - Accessory	Description
3 — 4 GND-OIMP	NO	OUTER SIDE OPENING	Contact for connection of external detection radar. The closure of the contact activates an opening operation. NB: this command is only active with the COM400MKB-MHB function selector switch.
3 — 5 GND-O/C	NO	OPENING / CLOSING COMMAND	The closure of the contact activates an opening operation. The door stays open until a new command is given. If the door does not receive any command, it closes automatically after 15 minutes of inactivity. Automatic closing cannot be adjusted using the HOT trimmer; it is factory-set. The automatic closing time can be modified from 15 min to endless (∞), by altering the pre-configured parameters as explained in chapter 13. The opening/closing command only works in TWO-WAY mode. Modify the operating mode to CLOSED door or ONE-WAY opening, altering the pre-configured parameters as explained in chapter 13.
3 — 6 GND-KEY	NO	KEY OPENING	The closure of the contact activates an opening operation. This command is always active, even when the COM400MHB/MKB function selector switch or ON-OFF-HOLD OPEN switch is installed. Can be used for opening from night/CLOSED mode. If the selector is in the door CLOSED position, the automation meets the Low Energy regulation. If the selector is in the door CLOSED position and a KEY command is given, the automation meets the Low Energy regulation. The automatic closing time following a KEY command is controlled by the KHOT trimmer (from 1.5 s to 30 s). NB: this is the only command active in energy-saving mode.

Contact	Function - Accessory	Description
3 — 7 GND-KILL	NO	<p>EMERGENCY CLOSURE (FIRE BARRIERS)</p> <p>The closure of the contact activates an emergency closure operation. This command is active in every situation, and has priority over every other command. When the contact has reopened (with JUMPER J=ON), the door resumes operating as set by the selector.</p> <p> WARNING: if an EMERGENCY CLOSURE is activated, all the safety functions are ignored and the door closes. People or objects in the path of the door during the closing operation could suffer serious injury or damage.</p> <p>This function is generally used to cut off a specific area in the case of a fire.</p> <p>NB: this command can be combined with an emergency button.</p> <p>The output contact can be changed from NO to NC by altering the pre-configured parameters, as explained in chapter 13.</p> <p>If the NC contact is selected the KILL contact needs to be connected to clamp 4 (QTST) of the card, DAB905ESA.</p> <p>The operation of the block during the emergency closure can be selected from the pre-set parameters explained in chapter 13.</p> <p>A panic bar can be installed in combination with a magnetic block on the fire barrier.</p> <p>In the event of a fire alarm or a power supply failure, the panic bar keeps the closed door blocked. In the case of escape routes, the panic bar can be manually released.</p> <p>Configure the relay contact of the DAB905ESA card, choosing parameter 11, 12 or 13 as explained in chapter 13.</p>
4 — 7 QTST-KILL	N.C.	
3 — 7 GND-KILL	NO	<p>"NURSE & BED" FUNCTION</p> <p>In installations with parallel doors, the "NURSE & BED" function can be enabled by adjusting contact 3-7 on the SLAVE door control panel.</p> <p>With 3-7 closed, opening of the MASTER door is enabled (NURSE function):</p> <ul style="list-style-type: none"> • by issuing a KEY, IIMP, OIMP, O/C command to the MASTER door; • or by issuing an IIMP or OIMP command to the SLAVE door <p>With 3-7 closed, opening of both doors (BED function) is enabled via an O/C command given to the SLAVE door.</p>  <p>NB: make sure the KILL contact is NO. If this is not the case, modify the parameters as explained in chapter 13.</p> <p>If the PUSH AND GO function is enabled, the "BED" function can also be activated by manually pushing the SLAVE door. The door will open automatically.</p>
3 — 7 GND-KILL	NO	INTERLOCKED DOORS
3 — 8 GND-KRST	NO	EMERGENCY OPENING
3 — 9 GND-UNL	NO	DOOR RELEASED SIGNAL
3 — 10 GND-OFF	NO	DOOR CLOSED

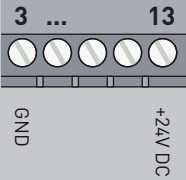
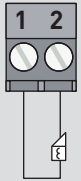
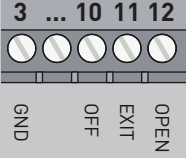
17.2 Outputs and accessories



Output	Description
	<p>Output for the power supply to the accessories 24V \approx 700 mA max. NB: the maximum absorption of 700 mA corresponds to the sum of all the accessories installed.</p>
	<p>Output for connecting an electric lock / electric strike. Select the type of power supply using the DIP1 and the type of electric lock / electric strike using the DIP2. NB: with DIP2 set to OFF and no COM400 function selector switch (or the latter in two-way mode), output 1-2 is permanently powered so that the door can be opened. If, on the other hand, you want to lock the door wing with the door closed, set the selector to one-way mode or make a jumper GND-EXIT (3-11). In this condition, output 1-2 is powered throughout the first 10° of door opening. With DIP2 set to ON, the behaviour will be the same except for the fact that output 1-2 will always be unpowered in two-way mode and throughout the open/close operation in one-way mode.</p>
	<p>Output for connecting the function selector switch. If the function selector switch is on OFF, the Push and Go function is disabled. If a function selector switch is installed, disconnect the ON/OFF/HOLD switch (if present). If the function selector switch is NOT installed and an electric lock / electric strike is present, set DIP2=ON and connect a jumper between 3-GND and 11-EXIT.</p>
<p>i For more information, refer to the COM400MKB-MHB selector manual.</p>	
<p>BATTERY</p> 	<p>BATTERY KIT If no mains power supply is available, the battery kit will guarantee operation in "energy-saving" mode. If no mains power supply is available, the door only operates with the key switch connected to 3 GND -6 KEY. In "energy-saving" mode, the door can remain stationary for up to a week while waiting for the KEY command. The following sensors are not active during "energy saving" operation: -OPD motion sensor -PIMP reversal safety contact -PDET opening safety device In this mode (on automations connected in parallel), connect the batteries only to the MASTER automation fitted with DAB905ESE. By changing the pre-configured parameter group, you can set the battery kit to CONTINUITY mode. If no mains power supply is available, the door operates normally until the batteries are fully discharged. In this mode (on automations connected in parallel), connect the batteries to both the automations fitted with DAB905ESE. NOTE: for charging purposes, the battery kit must be connected to the control panel at all times. A new kit with fully-charged batteries can usually open and close a door up to 300 times consecutively in CONTINUITY mode. If you want to check the battery kit is working correctly, set DIP5=ON. In the event of a battery alarm, the DAB205CU control panel LED will flash twice.</p>
<p>i Monitoring of batteries must always be reset when batteries are replaced. To RESET press and hold the LRN button while battery mode is active [with mains power supply disconnected].</p>	
<p>An acoustic/light alarm signal can be connected to terminals 6-7-8 on the DAB905ESA card.</p>	

17.3. Adjustments

17.3.1 Trimmers

Trimmer	Description
	Adjustment of the opening delay time, from 0 s to 3 s. With DIP3=ON, the door release is active throughout the opening delay.



17.3.2 Dip-switches

DIP	Description	OFF 	ON 
DIP1 (*)	Power supply to the electric lock / electric strike	12V \Rightarrow max. 1.2 A	24V \Rightarrow max. 600 mA
DIP2 (*)	Type of electric lock / electric strike	Normal The electric lock / electric strike is usually kept unpowered.	Anti-panic The electric lock / electric strike is usually kept powered. When it is unpowered, the door can be opened.
DIP3 (*)	Release	Disabled	Enabled during the time set by the delay time adjustment trimmer.
DIP4	Electric lock / Electric strike coupling	Disabled	Enabled When it approaches the closing stop, the door increases its force/speed to ensure correct closure on the electric lock / electric strike.
DIP5	Battery test	Disabled	Enabled



(*) Launch the SELF-LEARNING procedure (see paragraph 12.1) every time the DIP statuses are altered.

17.3.3 Jumpers

	Description	OFF 	ON 
	Emergency closure reset (FIRE BARRIERS ONLY)	Manual (with 3 GND - 8 KRST connected or DAB905RSD).	Automatic

17.4 Advanced settings available on the control panel version indicated, or subsequent versions



Increased thrust force on closure when an electric lock is fitted

1. Disconnect batteries if any.
2. Disconnect the mains.
3. Press the LEARN BUTTON (LRN) and keep it depressed.
4. Connect the mains.
5. Watch the ERROR LED.



6. Release the LEARN BUTTON after 5 flashes (LED is out).
7. Identify the current lock kick status:
The ERROR LED flashes an amount of short flashes that correspond to the status number.
After a short pause the LED will repeat the status number and so on.

8. Changing the status:

If you push the LEARN BUTTON once, the status number will increase.

When you have reached the highest status number it will start at number one again.

- Push the button until you get the requested lock kick status, 1=Basic (default), 2=Enhanced
- Disconnect the mains

Next time the mains is connected, the operator will use the new status setting.

18. Extension unit DAB905ESA (optional)

There is a command extension card for managing motion sensors, alarm indications and door status.

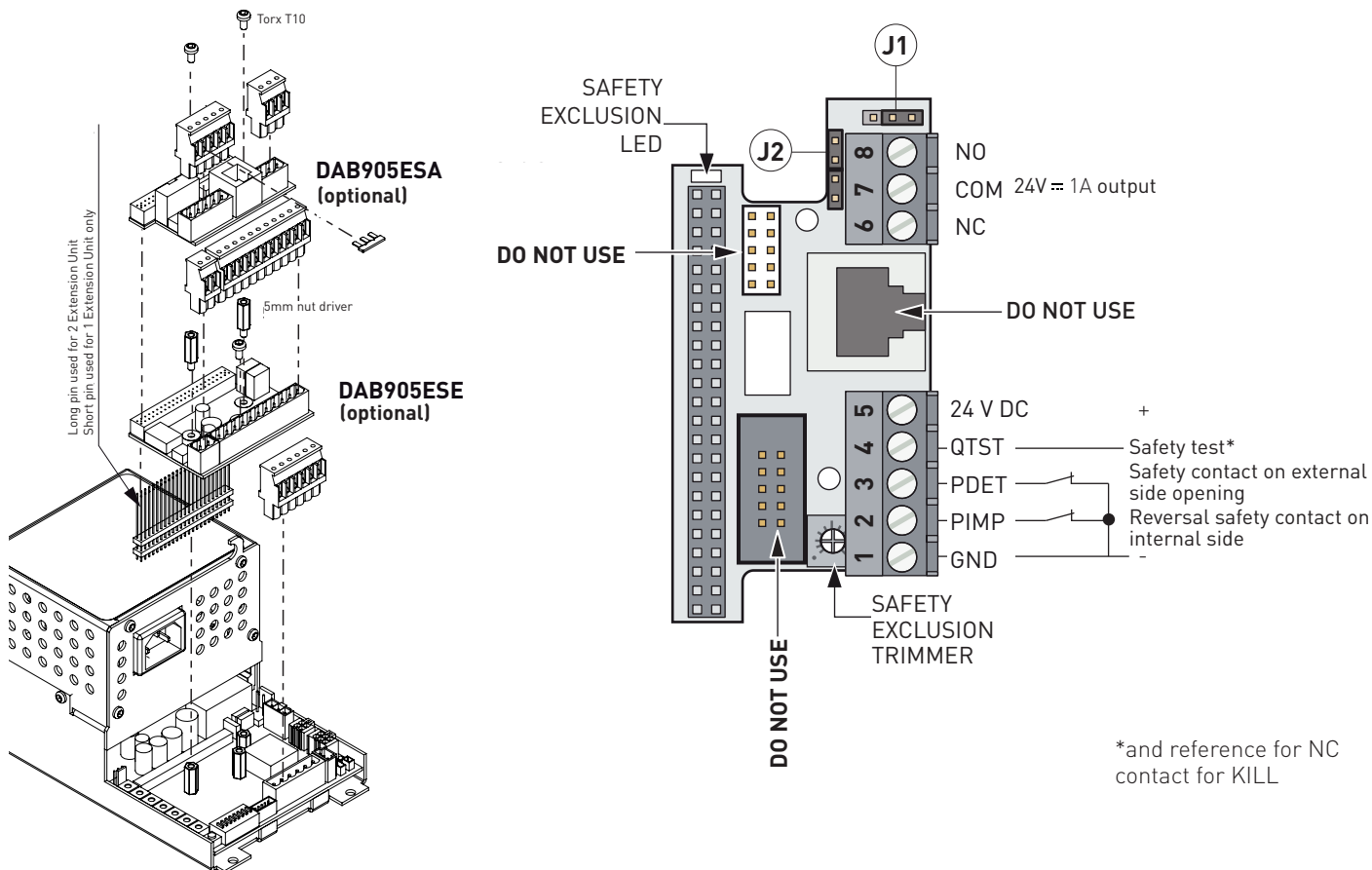

i Fix the label to the terminal board, taking care to apply it in the correct direction (see the figure above).

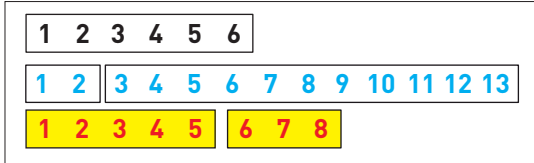



i Remove the jumpers if a safety sensor is connected to terminals 1-2 and 1-3.

18.1 Commands

Contact	Function - Accessory	Description
1 — 2 GND-PIMP	NC REVERSAL SAFETY CONTACT INTERNAL SENSOR	The opening of the contact during the closure manoeuvre causes the movement to invert (reopening). NB: the opening of the contact of the motion sensor installed on double doors causes both doors to re-open. The sensor is not active in DOOR CLOSED mode (set via the function selector switch), or when the door is opened manually due to a power failure or emergency closure (KILL).
1 — 3 GND-PDET	NC OPENING SAFETY DEVICE EXTERNAL SENSOR	The opening of the contact causes the movement to stop during the opening phase. When the contact closes again, the automation resumes the interrupted opening operation. If the automation is closed, the opening of the contact prevents the opening operation. Adjust the safety exclusion trimmer so that the sensor does not detect the wall during the opening phase. During the opening phase, the safety sensor takes priority over the motion sensor. NB: the opening of the contact of the motion sensor installed on double doors causes both doors to stop, except in the case of double exit doors. Modify the operation of the double doors by changing the pre-configured parameters as explained in chapter 13. The sensor is not active in DOOR CLOSED mode (set via the function selector switch), or when the door is opened manually. In this situation, the automation meets the requisites of the "Low Energy" directive.
5-4 24V-QTST	SAFETY TEST	Connect the QTST terminal of the control panel to the corresponding test terminal on the safety device. A test will be carried out on the safety device before every operation.

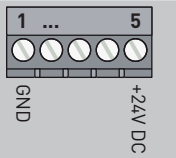
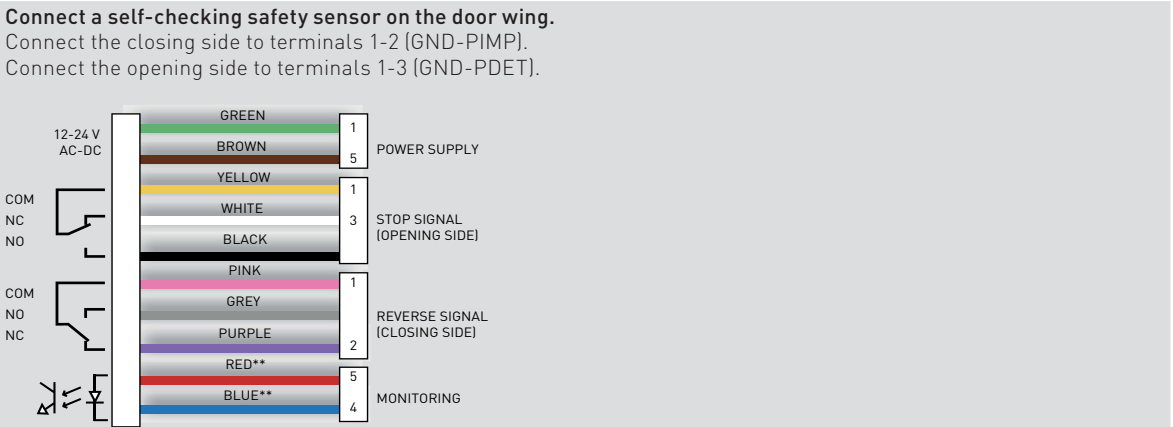
18.2 Outputs and accessories

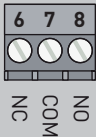
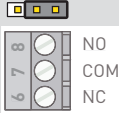
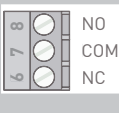









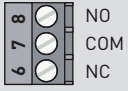

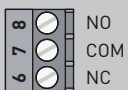
Output	Description
	<p>Output for the power supply to the accessories 24V ≈ 400 mA max. NB: the maximum absorption of 400 mA corresponds to the sum of all the accessories installed.</p>
<p>SAFETY SENSOR</p> 	<p>Connect a self-checking safety sensor on the door wing. Connect the closing side to terminals 1-2 (GND-PIMP). Connect the opening side to terminals 1-3 (GND-PDET).</p> <p>NB: in the event of a safety sensor fault during opening, the door closes and stays closed. It can only be opened manually. In the event of a safety sensor fault during closing, the door stays open. By switching the function selector switch to DOOR CLOSED, the door can operate in Low Energy mode. It can only be opened manually.</p> <div style="background-color: #00AEEF; color: white; padding: 5px; margin-bottom: 5px;">  Remove jumpers 1-2 and 1-3. </div> <div style="background-color: #00AEEF; color: white; padding: 5px;">  For more information, refer to the REM sensor manual </div>
	<p>Relay contact 24V ≈ 1A.</p> <div style="border: 1px solid #ccc; padding: 5px; margin-bottom: 5px;">  <p>The relay contact can be used as:</p> <ul style="list-style-type: none"> - an output for the parallel connection of the EMERGENCY CLOSURE command on several fire barriers; - an output for connecting a block with a power supply other than 12/24V DC; - an output for connecting an error warning device (light or acoustic). The COM-NO contact opens and the control panel detects an error (flashing LED on the DAB205CU control panel). <p>If there is no alarm/error, the COM-NO contact is closed. In the event of an error, refer to the "Alarms" paragraph (24.1).</p> </div> <div style="border: 1px solid #ccc; padding: 5px;">  <p>A device for indicating the open/closed door can be connected. The open/closed door position is adjusted by the opening safety exclusion trimmer. For a "door closed" indication, set the trimmer to its minimum. For a "door open" indication (from 55° to 90°), open the door with any opening command and adjust the trimmer until the LED on the DAB905ESA card lights up when the door is open (or is in the required opening position).</p> </div>

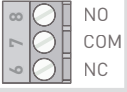
18.3. Adjustments

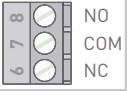
18.3.1 Trimmers

Trimmer	Description
	Adjustment of the opening safety exclusion, from 55° to 90°. During the door opening phase, this excludes the functioning of the safety device installed on the door wing connected to GND-PDET, so that the wall is not detected. When the safety device is excluded, the LED lights up.

18.3.2 Jumpers

J1	 	Indication of external error / Output for parallel connection of Emergency Closure (KILL) / Block output
	 	Indication of door open/closed
J2	OFF  ON  	Test on external sensor (GND-PDET)
	ON  OFF  	Test on internal sensor (GND-PIMP)
	ON  ON  	No test
	OFF  OFF  	Test on internal and external sensors (GND-PIMP / GND-PDET)

18.3.3 Signals

	ON 	OFF 
LED	Opening safety device disabled	Opening safety device enabled

19. Example of an application

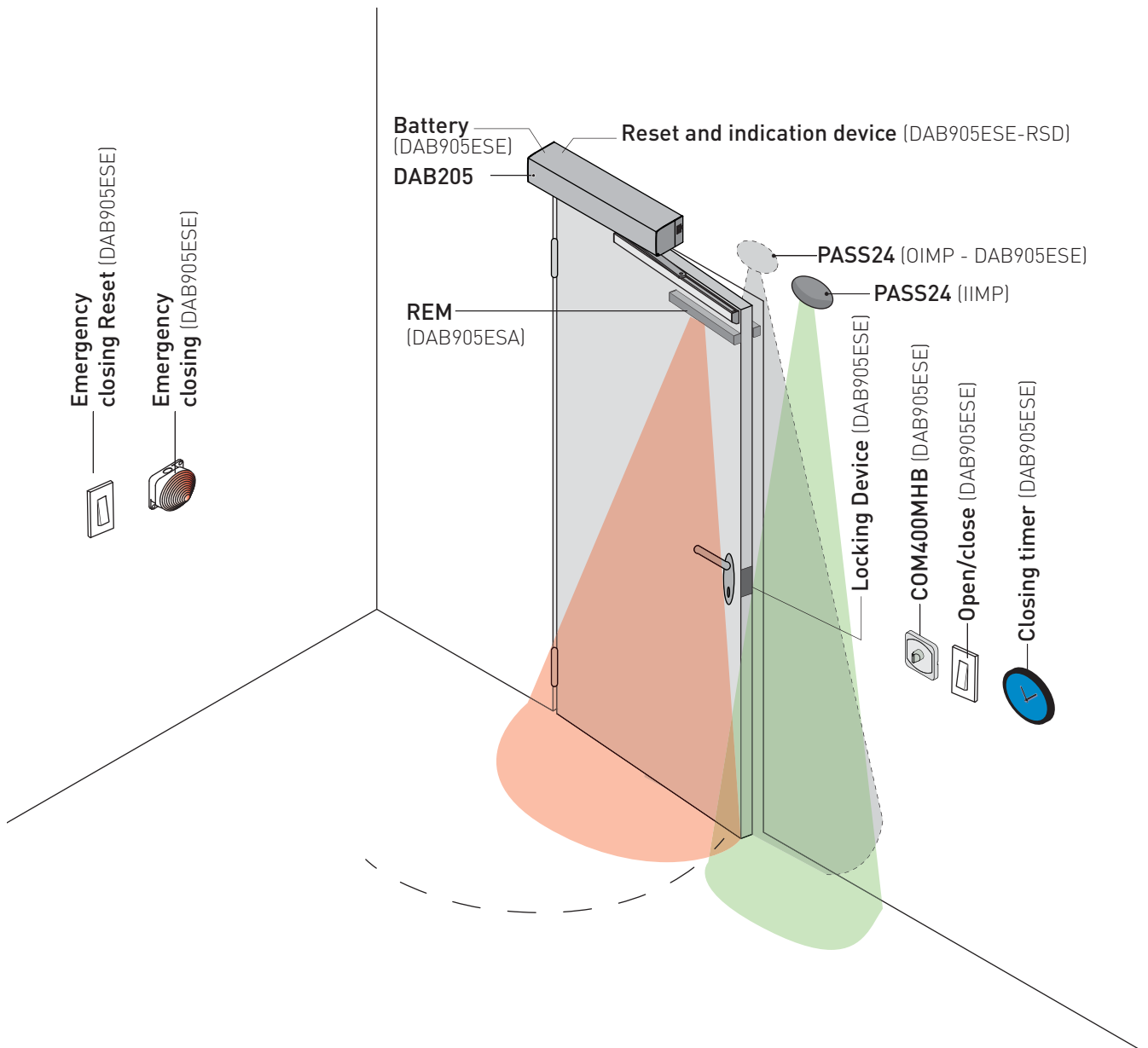

20. Example of an application DAB905RSD

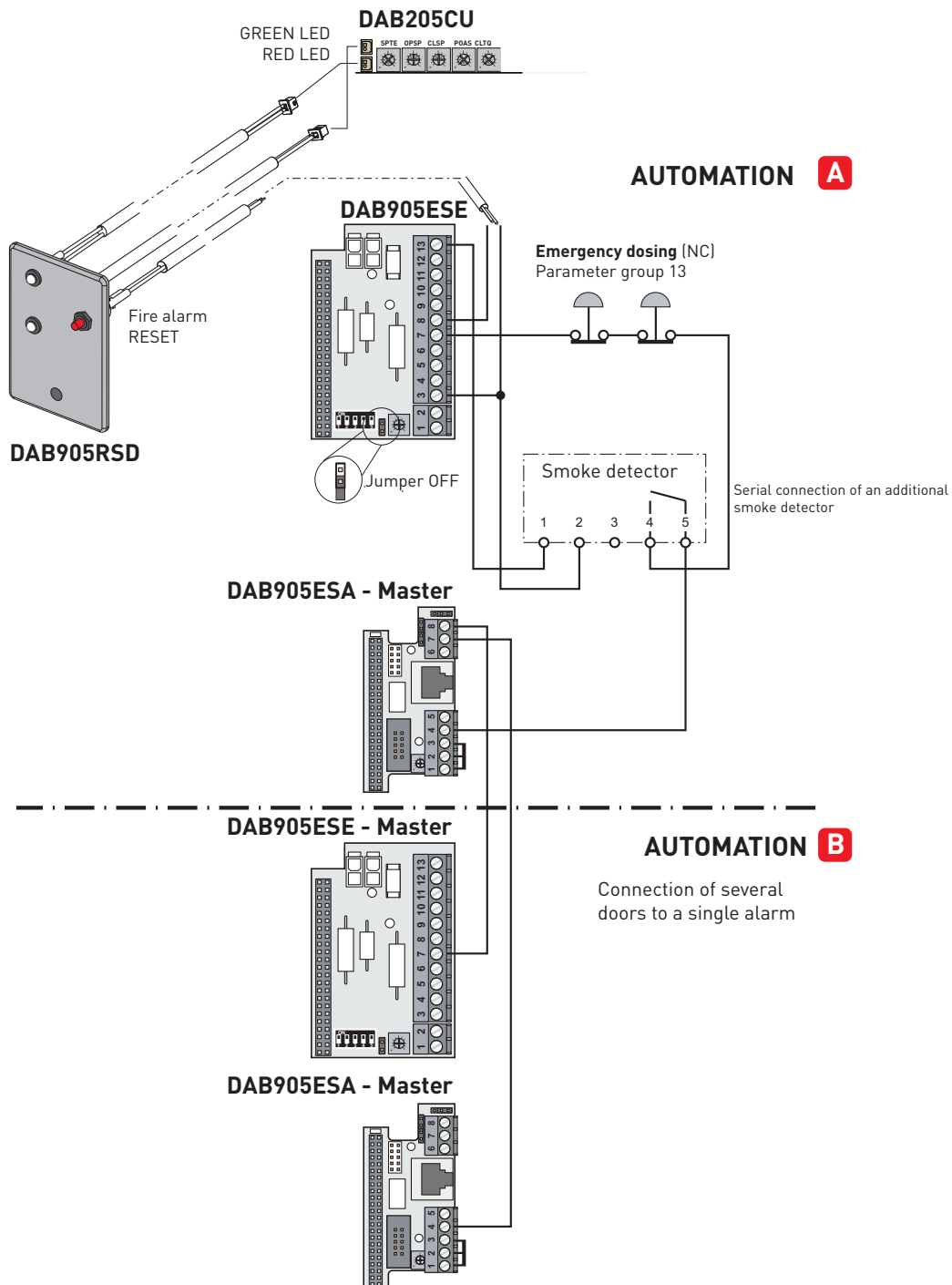
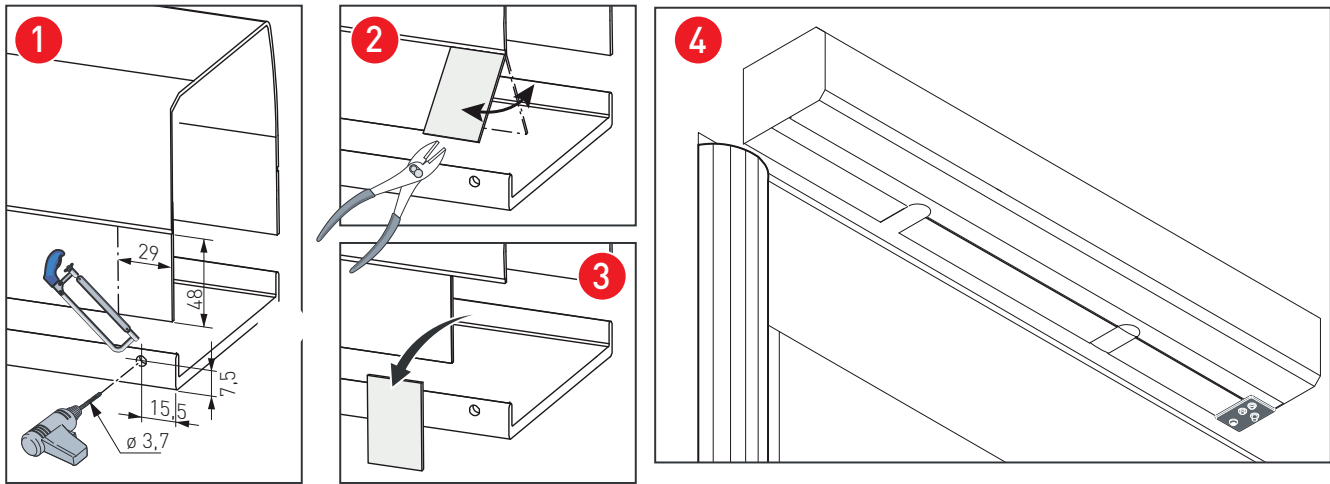

21. Parallel automations (DAB905SYN)

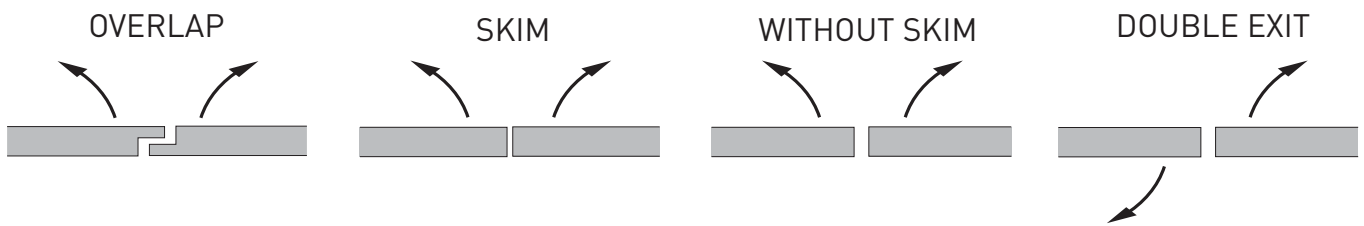

Connect the two automations to the plug on the control panel, using the synchronisation cable (DAB905SYN). Depending on the type of installation, cut the jumpers on the MASTER or SLAVE cable, as shown in the table:



The MASTER automation is the one that opens first.

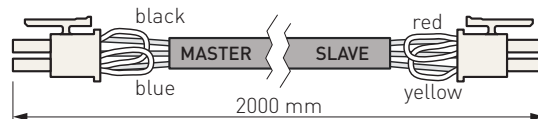

Operating mode		Type of application		Jumper to be cut	
Opening	Closure	Overlap	Skim	MASTER	SLAVE
Synchronous	Synchronous	NO	NO	/	/
Synchronous	Asynchronous	YES	NO	BLACK	/
Asynchronous	Asynchronous	YES	YES	/	RED
Double exit		/	/	BLACK	RED

21.1 Settings

Operating mode	Settings	
	MASTER	SLAVE
Program selection	X	
Opening time	X	
Closure time	X	
Closure time adjustment	X	
Closure / Opening attempt when the door is obstructed	X	
Enable / Disable PAG	X	
Level of servo-assistance	X	X (*)
Closure force	X	X (*)
Pulse of motion sensor or mat	X	
Selection of operating mode during battery functioning	X	
Lock/release signal tension	X	X
Block powered / Unpowered	X	X
Enable / Disable block release	X	X
Open door delay	X	X
Enable / Disable snap block	X	X

(*) In double exit doors, these functions have to be set separately on the MASTER and SLAVE doors because the arm system and air pressure may differ.



- The electric locks / electric strikes must be connected to the MASTER and SLAVE control panels.
- The opening devices must be connected to either the MASTER or SLAVE control panel, or to both.
- The OPD motion sensor must be connected to the MASTER control panel except for double exit doors where each OPD motion sensor must be connected to the corresponding control panel
- The sensors fitted on the wing must always be connected to the corresponding control panel.

21.1 Example of installation of parallel doors (DAB905SYN)

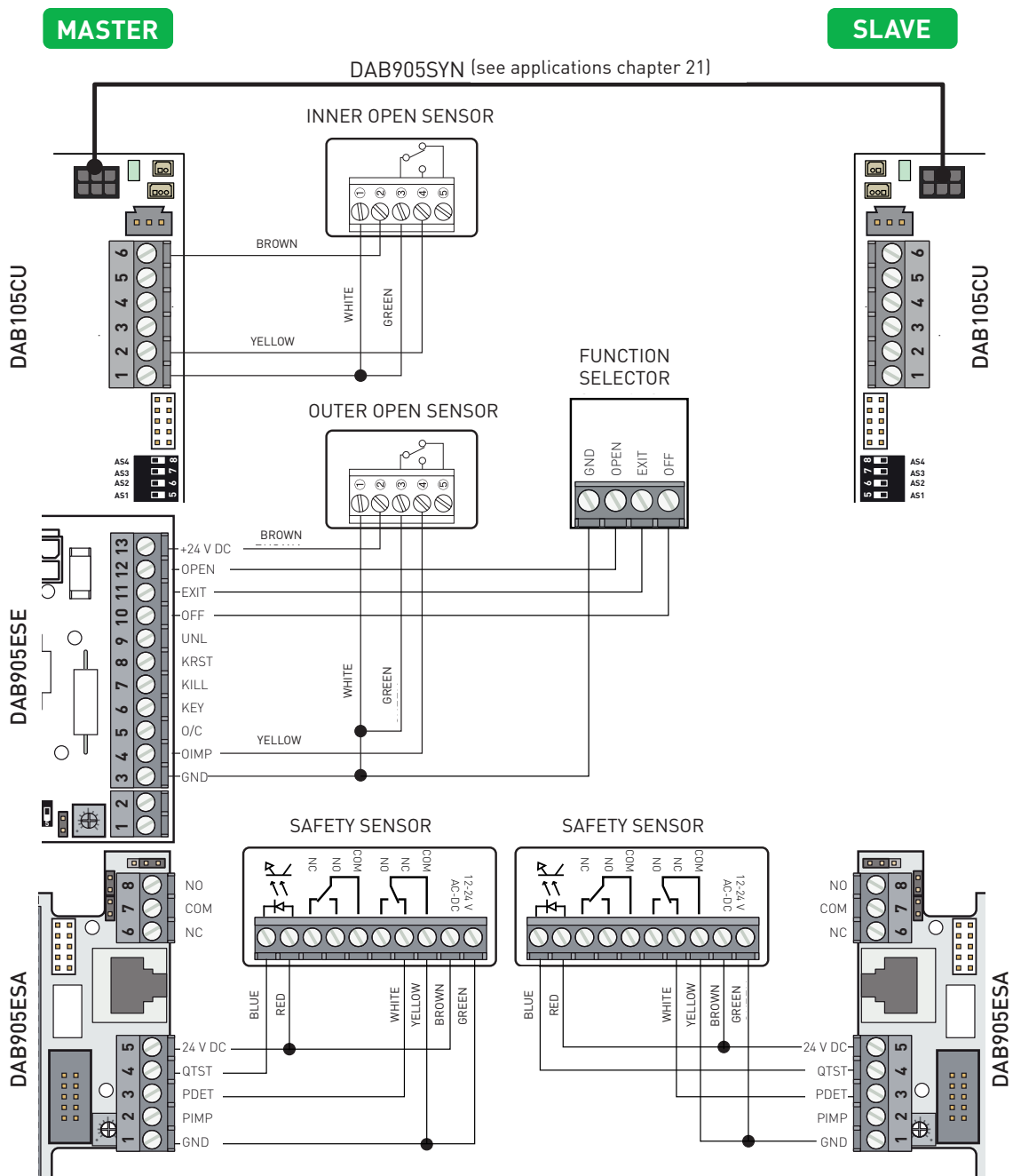
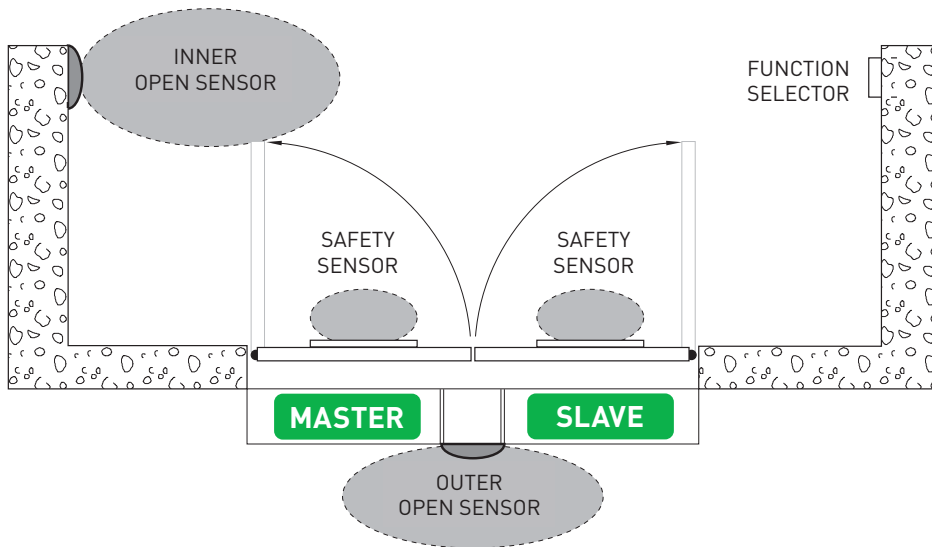

21.2 Interlocked automations

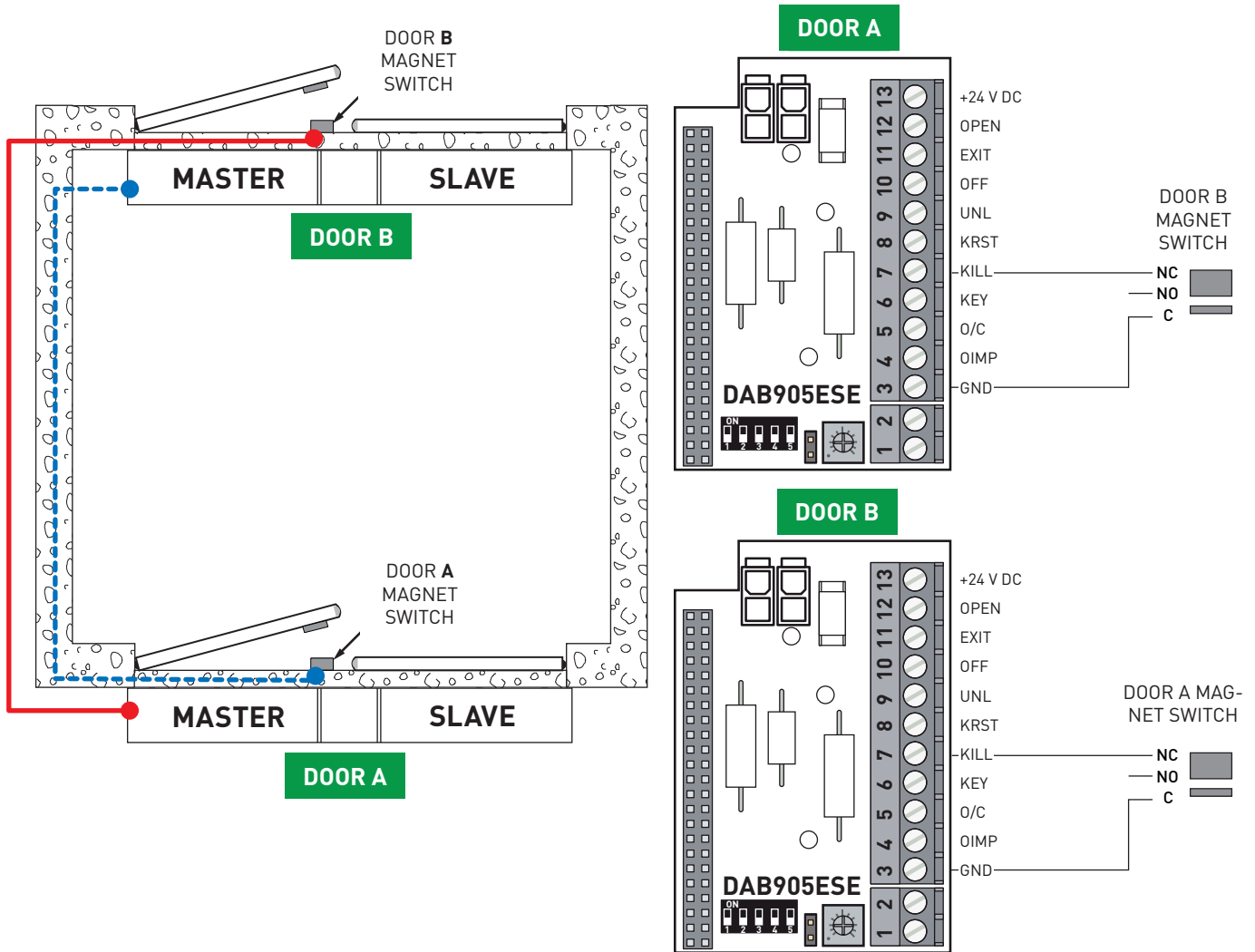

In applications for interlocked doors, a micro switch must be installed on the MASTER A automation in order to disable opening of the MASTER B automation and vice versa.

The KILL contact must be connected as indicated above so that the circuit is interrupted when the doors are closed and is not interrupted when the doors are open.

When both doors are closed, the 3-GND to 7-KILL circuit is interrupted. The first automation that opens closes the circuit and prevents the other automation from moving.

When the first automation has closed, the second automation can open by way of a second opening pulse.

NB: If a KILL command is given on the SLAVE automation, only the SLAVE door will stop.

NB: If single interlocked doors are installed, the same connections indicated above are used.

22. Electrical start-up



Before performing any type of operation, make sure that the automation is turned off and the batteries are disconnected.

The trimmers can only be adjusted with the automation idle.

1. Turn on the power supply.
2. Press the LRN button for automatic self-learning (see SELF-LEARNING, paragraph 12.1).
3. In the case of parallel installations, the self-learning procedure must be carried out on the MASTER door first, then the SLAVE door.
The self-learning procedures on the two doors can be carried out separately, before connecting the synchronisation cable.
In the case of parallel doors with overlap, the MASTER door must stay open until the SLAVE door has completed its self-learning procedure.
4. Set the automatic closing time by means of the HOT trimmer.
5. Adjust the opening speed with the OPSP trimmer.
6. Adjust the closing speed with the CLSP trimmer.
7. Connect the accessories and check they are functioning.

23. Routine maintenance plan

Perform the following operations and checks every 6 months, according to the intensity of use of the automation.

Disconnect the 230V~ power supply and batteries (if present), and position the ON-OFF switch on OFF:

- Clean and lubricate the moving parts.
- Check the securing screws are firmly in place.
- Check all the electrical connections.
- Make sure the batteries are in good working order.

Restore the 230V~ power supply and batteries (if present), and position the ON-OFF switch on ON:

- Check the stability of the door, and make sure it moves smoothly.
- Check the condition of the pivots or hinges.
- Make sure all the command and safety devices are working properly.



NB: for spare parts, see the spares price list.



Only use original spare parts when repairing or replacing products.

The installer must supply all information concerning the automatic, manual and emergency operation of the motorised door or gate, and must provide the user with the operating instructions.

The installer must prepare and keep a maintenance record showing all the routine and extraordinary maintenance work carried out.

24. Troubleshooting

Problem	Possible cause	Solution / Explanation
The door does not open		
a) The motor does not start	The switch is set to OFF	Change the position of the switch
	There is no mains power supply	Check the mains power supply
	The control panel does not work	Check the contacts on the control panel
	The motion sensor has been activated	Remove any objects from the detection area
	Emergency closure activated	Deactivate the emergency closure
	SPTe trimmer not set to 0°	Rotate the SPTe trimmer to 0°
b) The motor starts	Mechanical lock blocked	Release the lock
	Obstacle	Remove any obstacles
	Door stop jammed	Select block release
	The arm system is coming loose	Rotate the SPTe trimmer until the door stop is on the limit switch. Bring the door to its open position. Tighten the arm system. Rotate the SPTe trimmer to 0°
The door does not close	The switch is set to HOLD	Change the position of the switch
	The motion sensor contact has been activated	Remove any objects from the detection area
	Obstacle	Remove any obstacles
The spring pre-tensioning on the automatic system is unrecognised	Too many pre-tensioning adjustments have been made	<ol style="list-style-type: none"> 1. Rotate the SPTe trimmer until the end stop comes loose. 2. Remove the end stop and the arm system. 3. Disconnect the mains power supply and let the spring close the door. 4. Disconnect the motor cable. 5. Replace the arm system and locate the non-pretensioning point by moving the door wing backwards and forwards. 6. Loosen the arm. 7. Reconnect the motor cable. 8. Adjust the SPTe trimmer to 180° and wait for the rotation shaft to stop turning. Repeat the operation 4 more times before restoring the power supply. The spring will stretch by two rotations = 720°. 9. Reconnect the mains power supply. The automation sets the spring tension at 720° 10. Fix the end stop on the closure limit switch. 11. Set the SPTe trimmer to 0°. The automation is factory-set. 12. See chapter 11 for more adjustments.

26. Signs

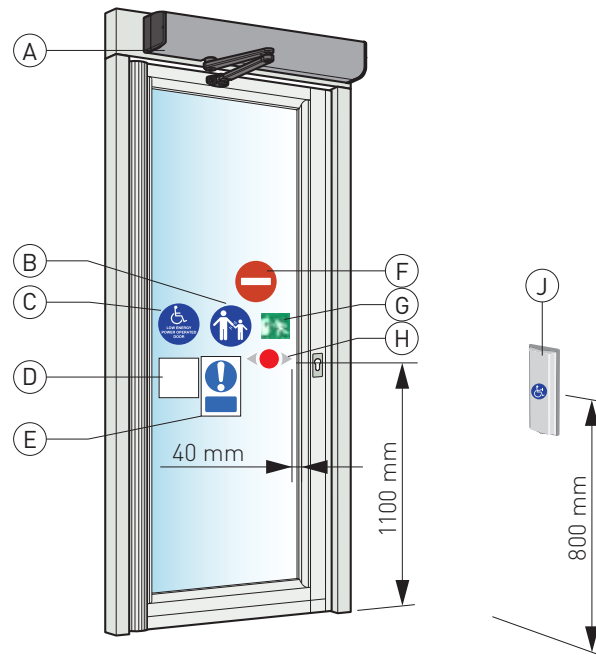

Make sure the signs are in good condition, and attach them.

Obligatory indicates that this sign is required by the European directives and equivalent national legislation outside the EEC.

Ref.		Description
A		Product label. Obligatory.
B		Supervision of children. Obligatory, if applicable. Attach to both sides of the door. Attach to doors used by children, the elderly and disabled (as shown by a risk analysis).
C		Automation suitable for the transit of disabled people. Recommended, if applicable. Attach to both sides of the door.
D		Automatic door. Obligatory in the UK only.
E		Do not block the passageway. Obligatory in the UK only.
F		No access. Indicates one-way transit. Obligatory in the UK and USA only, if applicable.
G		Emergency break-out. Obligatory if approved for escape routes.
H		Door label. Obligatory, if applicable. Warns of the presence of glass door wings. Attach to all mobile glass door wings.
J		The automation can be activated by disabled people. Recommended, if applicable.

All the rights concerning this material are the exclusive property of Entrematic Group AB.

Although the contents of this publication have been drawn up with the greatest care, Entrematic Group AB cannot be held responsible in any way for any damage caused by mistakes or omissions in this publication. We reserve the right to make changes without prior notice. Copying, scanning or changing in any way is expressly forbidden unless authorised in writing by Entrematic Group AB.

ENTRE//MATIC



Entrematic Group AB
Lodjursgatan 10
SE-261 44, Landskrona
Sweden
www.entrematic.com

